

2" Elima-Matic Bolted Non-Metallic

with Metallic Center Section

E2

E2 Non-Metallic Pumps

- Polypropylene
- PVDF

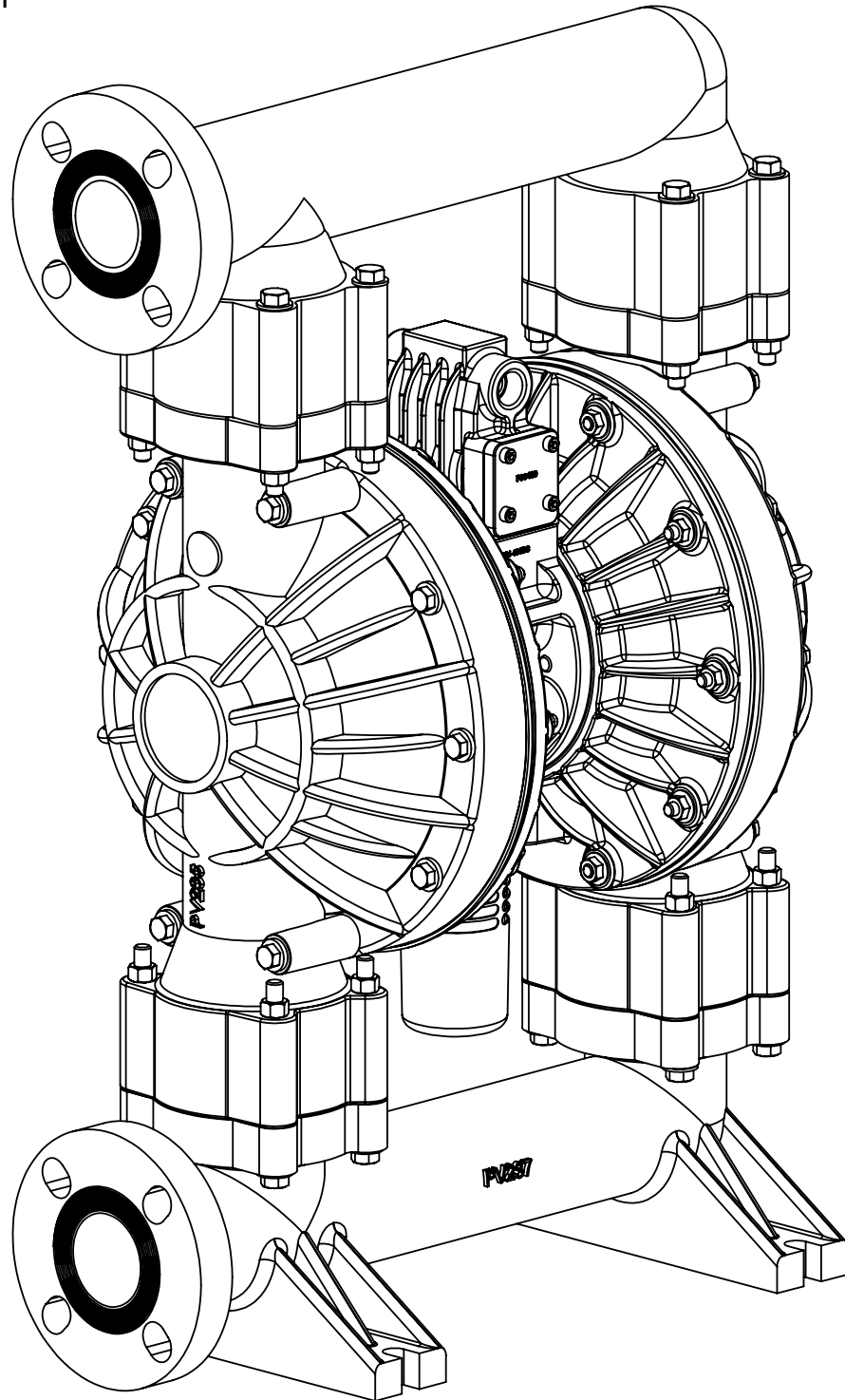

1: PUMP SPECS

2: INSTAL & OP

3: EXP VIEW

4: WARRANTY

Safety Information

IMPORTANT



Read the safety warnings and instructions in this manual before pump installation and start-up. Failure to comply with the recommendations stated in this manual could damage the pump and void factory warranty.



When the pump is used for materials that tend to settle out or solidify, the pump should be flushed after each use to prevent damage. In freezing temperatures the pump should be completely drained between uses.

CAUTION



Before pump operation, inspect all fasteners for loosening caused by gasket creep. Retighten loose fasteners to prevent leakage. Follow recommended torques stated in this manual.



Nonmetallic pumps and plastic components are not UV stabilized. Ultraviolet radiation can damage these parts and negatively affect material properties. Do not expose to UV light for extended periods of time.



WARNING
Pump not designed, tested or certified to be powered by compressed natural gas. Powering the pump with natural gas will void the warranty.

WARNING



When used for toxic or aggressive fluids, the pump should always be flushed clean prior to disassembly.



Before maintenance or repair, shut off the compressed air line, bleed the pressure, and disconnect the air line from the pump. Be certain that approved eye protection and protective clothing are worn at all times. Failure to follow these recommendations may result in serious injury or death.



Airborne particles and loud noise hazards. Wear eye and ear protection.



In the event of diaphragm rupture, pumped material may enter the air end of the pump, and be discharged into the atmosphere. If pumping a product that is hazardous or toxic, the air exhaust must be piped to an appropriate area for safe containment.



Take action to prevent static sparking. Fire or explosion can result, especially when handling flammable liquids. The pump, piping, valves, containers and other miscellaneous equipment must be properly grounded.



This pump is pressurized internally with air pressure during operation. Make certain that all fasteners are in good condition and are reinstalled properly during reassembly.



Use safe practices when lifting

Grounding the Pump

To be fully groundable, the pumps must be ATEX Compliant. Refer to the nomenclature page for ordering information.

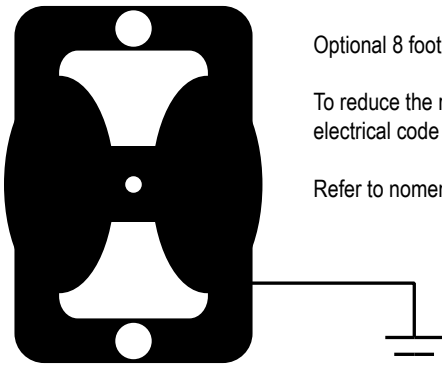

Optional 8 foot long (244 centimeters) Ground Strap is available for easy ground connection.

To reduce the risk of static electrical sparking, this pump must be grounded. Check the local electrical code for detailed grounding instruction and the type of equipment required.

Refer to nomenclature page for ordering information.

WARNING



Take action to prevent static sparking. Fire or explosion can result, especially when handling flammable liquids. The pump, piping, valves, containers or other miscellaneous equipment must be grounded.

Table of Contents

SECTION 1: PUMP SPECIFICATIONS.....1

- Nomenclature
- Performance
- Materials
- Dimensional Drawings

SECTION 2: INSTALLATION & OPERATION.....6

- Principle of Pump Operation
- Typical Installation Guide
- Troubleshooting

SECTION 3: EXPLODED VIEW.....9

- Composite Drawings
- Parts List
- Materials Code

SECTION 4: WARRANTY & CERTIFICATES13

- Warranty
- CE Declaration of Conformity - Machinery

1: PUMP SPECS

2: INSTAL & OP

3: EXP VIEW

4: WARRANTY

Explanation of Pump Nomenclature

Your Serial #: (fill in from pump nameplate) _____

Your Model #: (fill in from pump nameplate)

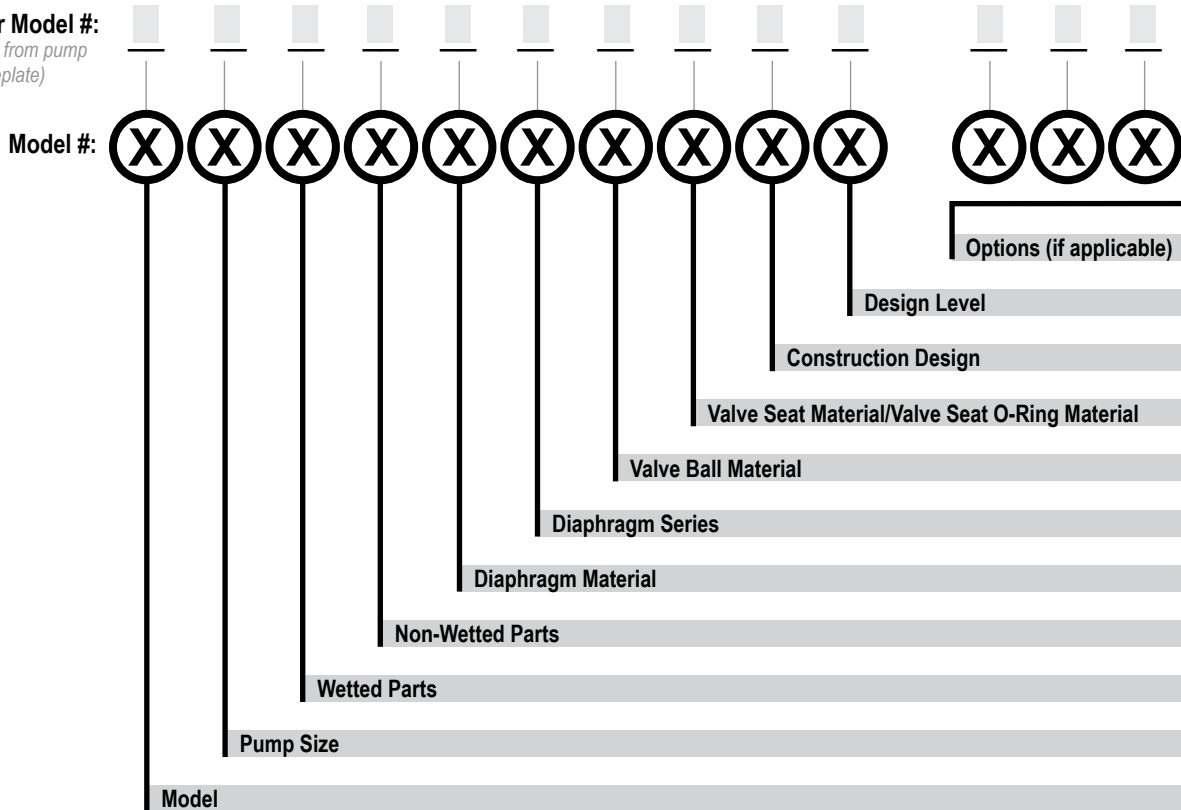

Model

E Elima-Matic
U Ultra-Matic
V V-Series
RE AirVantage

Pump Size

6 1/4"
8 3/8"
5 1/2"
7 3/4"
1 1"
4 1-1/4" or 1-1/2"
2 2"
3 3"

Wetted Parts

A Aluminum
C Cast Iron
S Stainless Steel
H Alloy C
P Polypropylene
K Kynar
G Groundable Acetal
B Aluminum (screen mount)

Non-Wetted Parts

A Aluminum
S Stainless Steel
P Polypropylene
G Groundable Acetal
Z PTFE-coated Aluminum
J Nickel-plated Aluminum
C Cast Iron
Q Epoxy-Coated Aluminum

Diaphragm Material

1 Neoprene
2 Nitrile (Nitrile)
3 FKM (Fluorocarbon)
4 EPDM
5 PTFE
6 Santoprene XL
7 Hytrel
9 Geolast
Y FDA Santoprene

Diaphragm Series

R Rugged
D Dome
X Thermo-Matic
T Tef-Matic (2-piece)
B Versa-Tuff (1-piece)
F FUSION (one-piece integrated plate)

Valve Ball Material Valve

1 Neoprene
2 Nitrile
3 (FKM) Fluorocarbon
4 EPDM
5 PTFE
6 Santoprene XL
7 Hytrel
8 Polyurethane
9 Geolast
A Acetal
S Stainless Steel
Y FDA Santoprene

Seat/Valve Seat O-Ring Material

1 Neoprene
2 Nitrile
3 (FKM) Fluorocarbon
4 EPDM
5 PTFE
6 Santoprene XL
7 Hytrel
8 Polyurethane
9 Geolast
A Aluminum w/ PTFE O-Rings
S Stainless Steel w/ PTFE O-Rings
C Carbon Steel w/ PTFE O-Rings
H Alloy C w/ PTFE O-Rings
T PTFE Encapsulated Silicone O-Rings
Y FDA Santoprene

Construction Design

9 Bolted
0 Clamped

Design Level

A
C

Miscellaneous Options

B BSP Tapered Thread
CP Center Port
ATEX ATEX Compliant
FP Food Processing
SP Sanitary Pump
HP High Pressure
OE Original Elima-Matic
F Flap Valve
HD Horizontal Discharge
3A 3-A Certified
UL UL Listed
OB Oil Bottle

*More than one option may be specified for a particular pump model.

Materials

Material Profile:	Operating Temperatures:	
	Max.	Min.
CAUTION! Operating temperature limitations are as follows:		
Conductive Acetal: Tough, impact resistant, ductile. Good abrasion resistance and low friction surface. Generally inert, with good chemical resistance except for strong acids and oxidizing agents.	190°F 88°C	-20°F -29°C
EPDM: Shows very good water and chemical resistance. Has poor resistance to oils and solvents, but is fair in ketones and alcohols.	280°F 138°C	-40°F -40°C
FKM: (Fluorocarbon) Shows good resistance to a wide range of oils and solvents; especially all aliphatic, aromatic and halogenated hydrocarbons, acids, animal and vegetable oils. Hot water or hot aqueous solutions (over 70°F) will attack FKM.	350°F 177°C	-40°F -40°C
Hytrel®: Good on acids, bases, amines and glycols at room temperatures only.	220°F 104°C	-20°F -29°C
Neoprene: All purpose. Resistance to vegetable oils. Generally not affected by moderate chemicals, fats, greases and many oils and solvents. Generally attacked by strong oxidizing acids, ketones, esters and nitro hydrocarbons and chlorinated aromatic hydrocarbons.	200°F 93°C	-10°F -23°C
Nitrile: General purpose, oil-resistant. Shows good solvent, oil, water and hydraulic fluid resistance. Should not be used with highly polar solvents like acetone and MEK, ozone, chlorinated hydrocarbons and nitro hydrocarbons.	190°F 88°C	-10°F -23°C
Nylon: 6/6 High strength and toughness over a wide temperature range. Moderate to good resistance to fuels, oils and chemicals.	180°F 82°C	32°F 0°C

Polypropylene: A thermoplastic polymer. Moderate tensile and flex strength. Resists strong acids and alkali. Attacked by chlorine, fuming nitric acid and other strong oxidizing agents.	180°F 82°C	32°F 0°C
PVDF: (Polyvinylidene Fluoride) A durable fluoroplastic with excellent chemical resistance. Excellent for UV applications. High tensile strength and impact resistance.	250°F 121°C	0°F -18°C
Santoprene®: Injection molded thermoplastic elastomer with no fabric layer. Long mechanical flex life. Excellent abrasion resistance.	275°F 135°C	-40°F -40°C
UHMW PE: A thermoplastic that is highly resistant to a broad range of chemicals. Exhibits outstanding abrasion and impact resistance, along with environmental stress-cracking resistance.	180°F 82°C	-35°F -37°C
Urethane: Shows good resistance to abrasives. Has poor resistance to most solvents and oils.	150°F 66°C	32°F 0°C
Virgin PTFE: (PFA/TFE) Chemically inert, virtually impervious. Very few chemicals are known to chemically react with PTFE; molten alkali metals, turbulent liquid or gaseous fluorine and a few fluoro-chemicals such as chlorine trifluoride or oxygen difluoride which readily liberate free fluorine at elevated temperatures.	220°F 104°C	-35°F -37°C
<i>Maximum and Minimum Temperatures are the limits for which these materials can be operated. Temperatures coupled with pressure affect the longevity of diaphragm pump components. Maximum life should not be expected at the extreme limits of the temperature ranges.</i>		
Metals:		
Alloy C: Equal to ASTM494 CW-12M-1 specification for nickel and nickel alloy.		
Stainless Steel: Equal to or exceeding ASTM specification A743 CF-8M for corrosion resistant iron chromium, iron chromium nickel and nickel based alloy castings for general applications. Commonly referred to as 316 Stainless Steel in the pump industry.		

1: PUMP SPECS

For specific applications, always consult the Chemical Resistance Chart.

AFTERMARKET PARTS

RIGHT PART, RIGHT NOW

Pumper Parts is your single source for parts that fit Air-Operated Double Diaphragm (AODD) pumps

- Wilden®
- ARO®
- Yamada®

Designed to perform equal to or greater than original equipment manufacture.



Phone: (419) 526-7296
 info@pumperparts.com
 www.pumperparts.com

Pumper Parts and its products are not affiliated with any of the original equipment manufacturers referenced herein. All original equipment manufacturers' names, colors, pictures, descriptions and part numbers are used for identification purposes only. Pumper Parts® is a registered trade name of IDEX Corporation. All other trademarks, registered trademarks and product names are the property of their respective owners. Yamada® is a registered trademark of Yamada Corporation. ARO® is a registered trade name of Ingersoll-Rand Company. Wilden® is a registered trade name of Wilden Pump and Engineering Company, a Dover Resources Company.

Performance

E2 - 2" Non-Metallic Bolted Pump – Metallic Center ELASTOMERIC AND TPE FITTED - Domed

Flow Rate

Adjustable to 0-177 gpm (670 lpm)

Port Size

Suction 2" ANSI, 150 Class (DIN 50)

Discharge 2" ANSI, 150 Class (DIN 50)

Air Inlet 1/2" NPT

Air Exhaust 1" NPT

Suction Lift

Dry 16' (4.9 m)

Wet 32' (9.8 m)

Max Solid Size (Diameter)

. 1/4" (6.3 mm)

Max Noise Level

. 96 dB(A)

Shipping Weights

Polypropylene 69 lbs (31.3 kg)

w/ center port options 73 lbs (33.1 kg)

PVDF 93 lbs (42.2 kg)

w/ center port options 100 lbs (45.4 kg)

1: PUMP SPECS

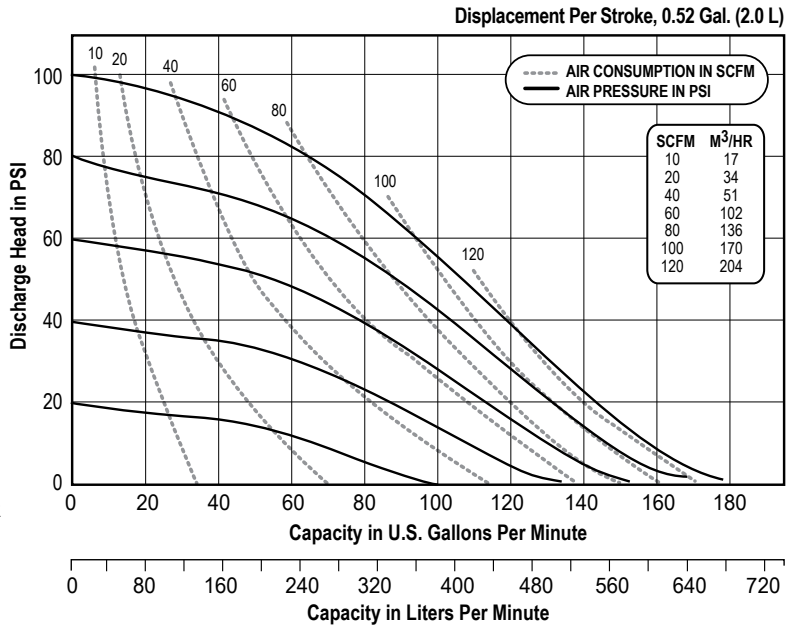
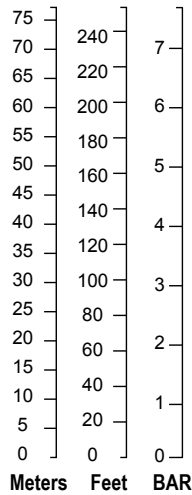

NOTE: Performance based on the following: elastomeric fitted pump, flooded suction, water at ambient conditions. The use of other materials and varying hydraulic conditions may result in deviations in excess of 5%.

E2 - 2" Non-Metallic Bolted Pump – Metallic Center PTFE FITTED

Flow Rate

Adjustable to 0-145 gpm (549 lpm)

Port Size

Suction 2" ANSI, 150 Class (DIN 50)

Discharge 2" ANSI, 150 Class (DIN 50)

Air Inlet 1/2" NPT

Air Exhaust 1" NPT

Suction Lift

Dry 8' (2.4 m)

Wet 30' (9.1 m)

Max Solid Size (Diameter)

. 1/4" (6.3 mm)

Max Noise Level

. 99 dB(A)

Shipping Weights

Polypropylene 69 lbs (31.3 kg)

w/ center port options 73 lbs (33.1 kg)

PVDF 93 lbs (42.2 kg)

w/ center port options 100 lbs (45.4 kg)

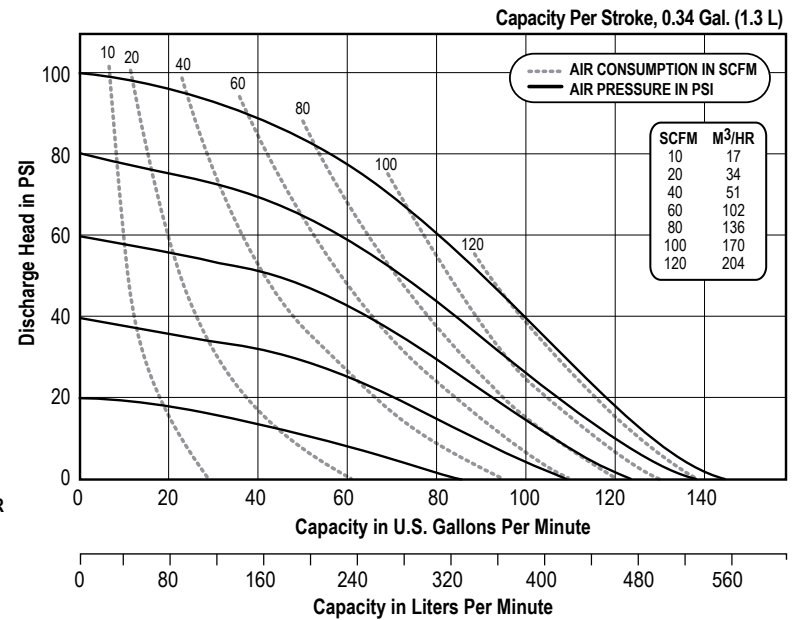
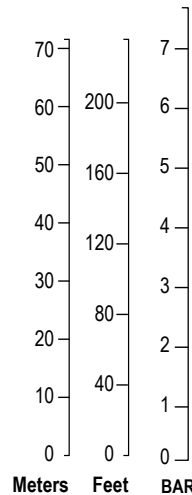

NOTE: Performance based on the following: elastomeric fitted pump, flooded suction, water at ambient conditions. The use of other materials and varying hydraulic conditions may result in deviations in excess of 5%.

Dimensional Drawings

E2 Non-Metallic Bolted

Dimensions in inches (mm dimensions in brackets)

The dimensions on this drawing are for reference only. A certified drawing can be requested if physical dimensions are needed.

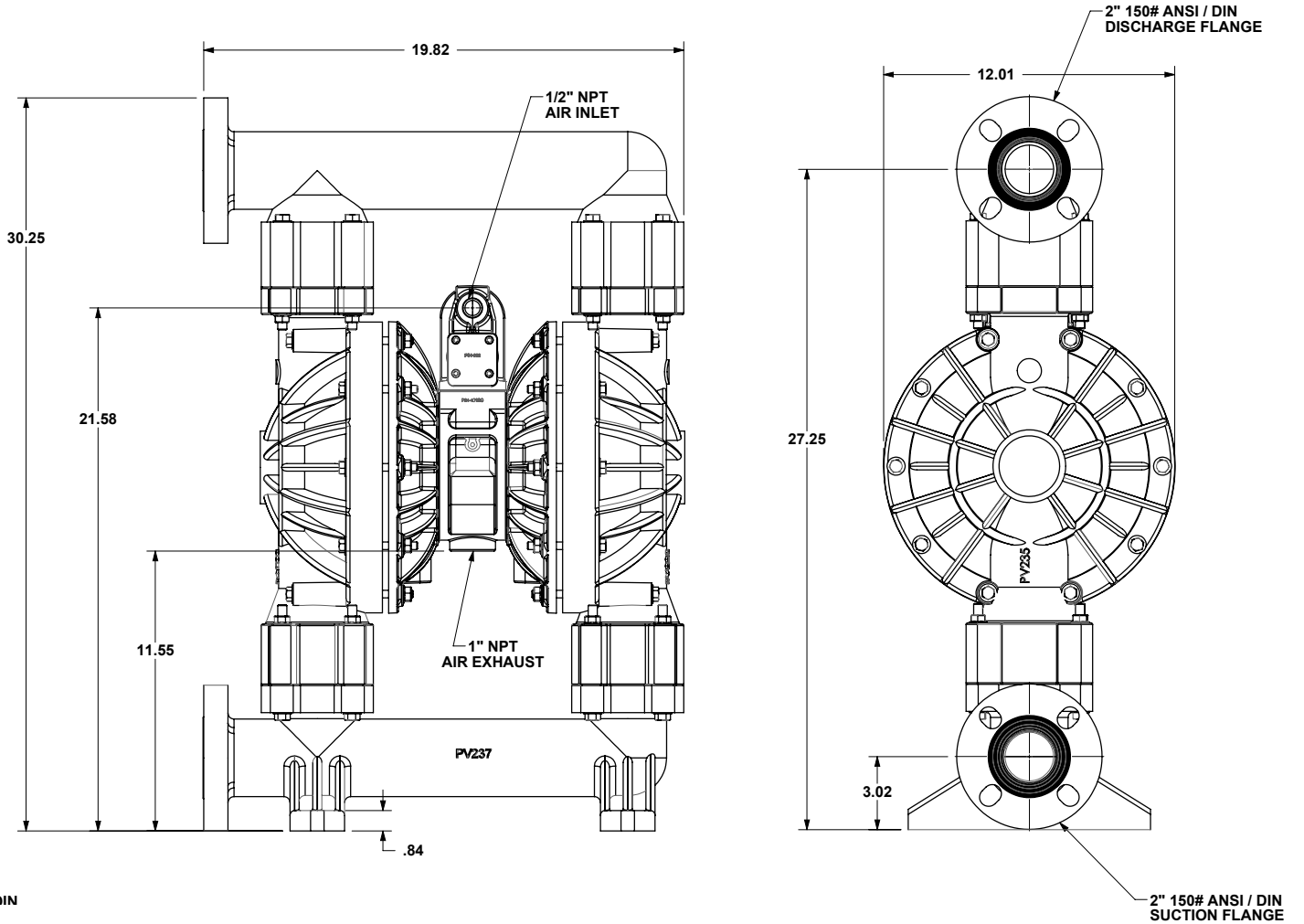

SI / DIN

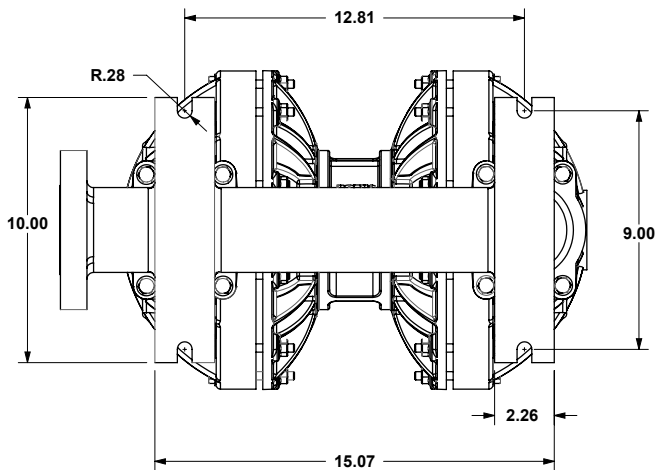

BOTTOM VIEW

1: PUMP SPECS

Dimensional Drawings

E2 Non-Metallic Bolted - Optional Center Porting

Dimensions in inches (mm dimensions in brackets)

The dimensions on this drawing are for reference only. A certified drawing can be requested if physical dimensions are needed.

1: PUMP SPECS

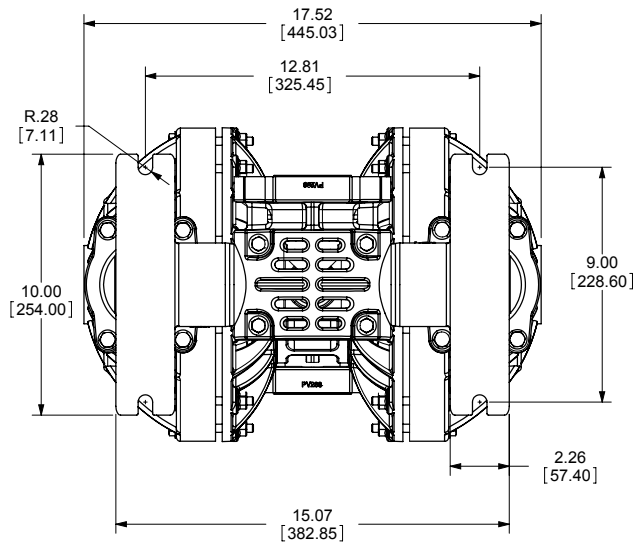
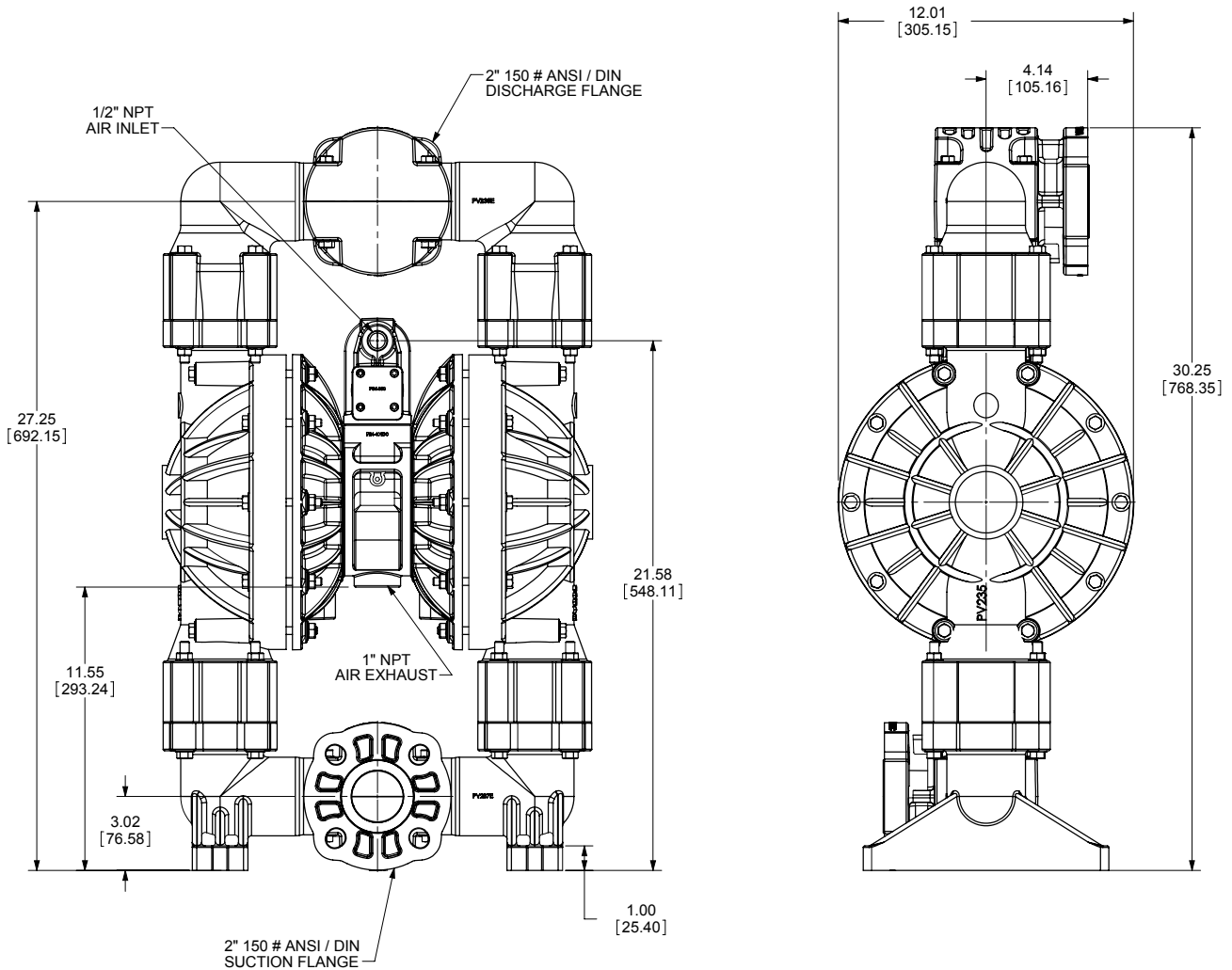

BOTTOM VIEW

Principle of Pump Operation

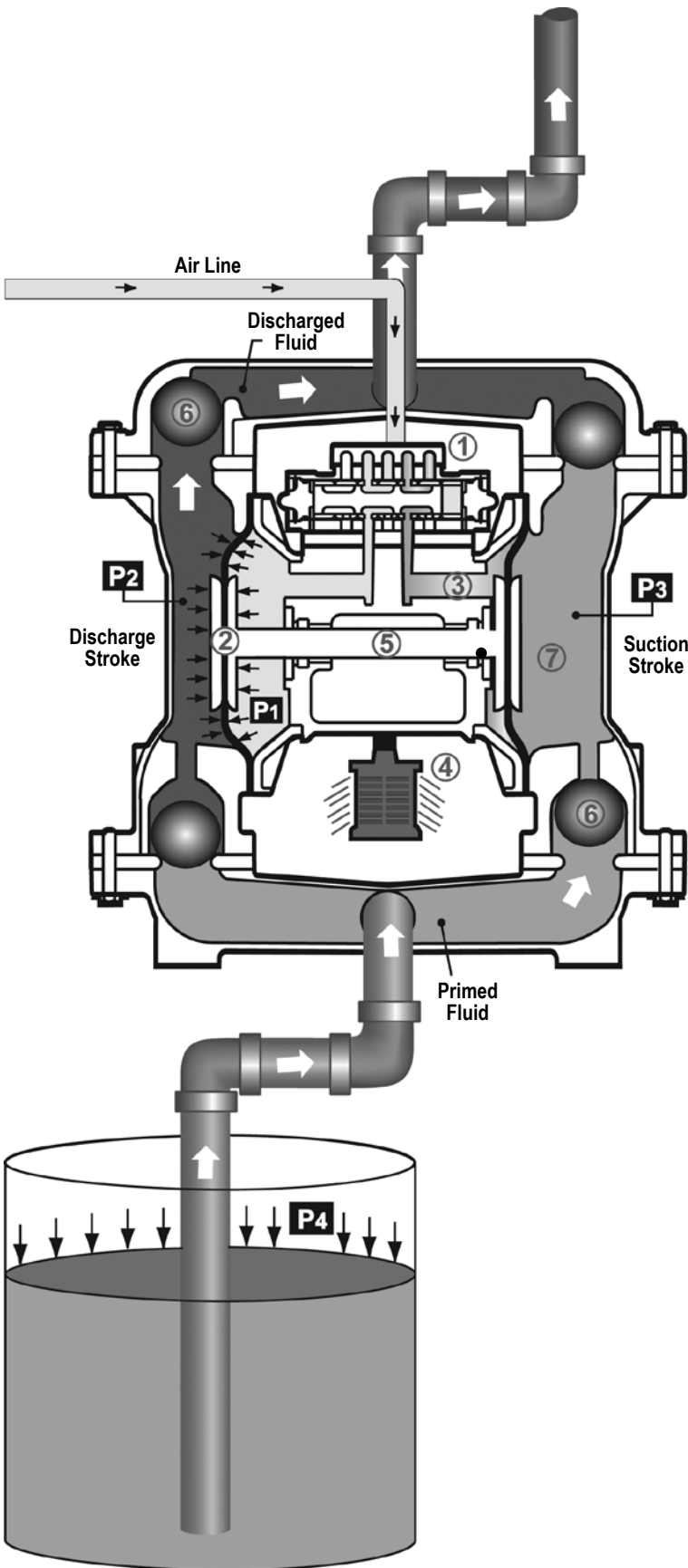

Air-Operated Double Diaphragm (AODD) pumps are powered by compressed air or nitrogen.

The main directional (air) control valve ① distributes compressed air to an air chamber, exerting uniform pressure over the inner surface of the diaphragm ②. At the same time, the exhausting air ③ from behind the opposite diaphragm is directed through the air valve assembly(s) to an exhaust port ④.

As inner chamber pressure (P1) exceeds liquid chamber pressure (P2), the rod ⑤ connected diaphragms shift together creating discharge on one side and suction on the opposite side. The discharged and primed liquid's directions are controlled by the check valves (ball or flap)⑥ orientation.

The pump primes as a result of the suction stroke. The suction stroke lowers the chamber pressure (P3) increasing the chamber volume. This results in a pressure differential necessary for atmospheric pressure (P4) to push the fluid through the suction piping and across the suction side check valve and into the outer fluid chamber ⑦.

Suction (side) stroking also initiates the reciprocating (shifting, stroking or cycling) action of the pump. The suction diaphragm's movement is mechanically pulled through its stroke. The diaphragm's inner plate makes contact with an actuator plunger aligned to shift the pilot signaling valve. Once actuated, the pilot valve sends a pressure signal to the opposite end of the main directional air valve, redirecting the compressed air to the opposite inner chamber.

SUBMERGED ILLUSTRATION

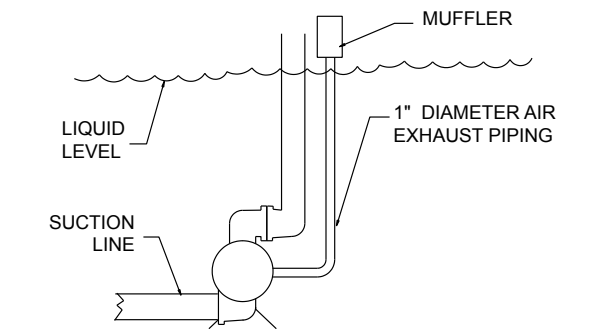

Pump can be submerged if the pump materials of construction are compatible with the liquid being pumped. The air exhaust must be piped above the liquid level. When the pumped product source is at a higher level than the pump (flooded suction condition), pipe the exhaust higher than the product source to prevent siphoning spills.

Recommended Installation Guide

Available Accessories:

1. Surge Suppressor
2. Filter/Regulator
3. Air Dryer

Note: Surge Suppressor and Piping must be supported after the flexible connection.

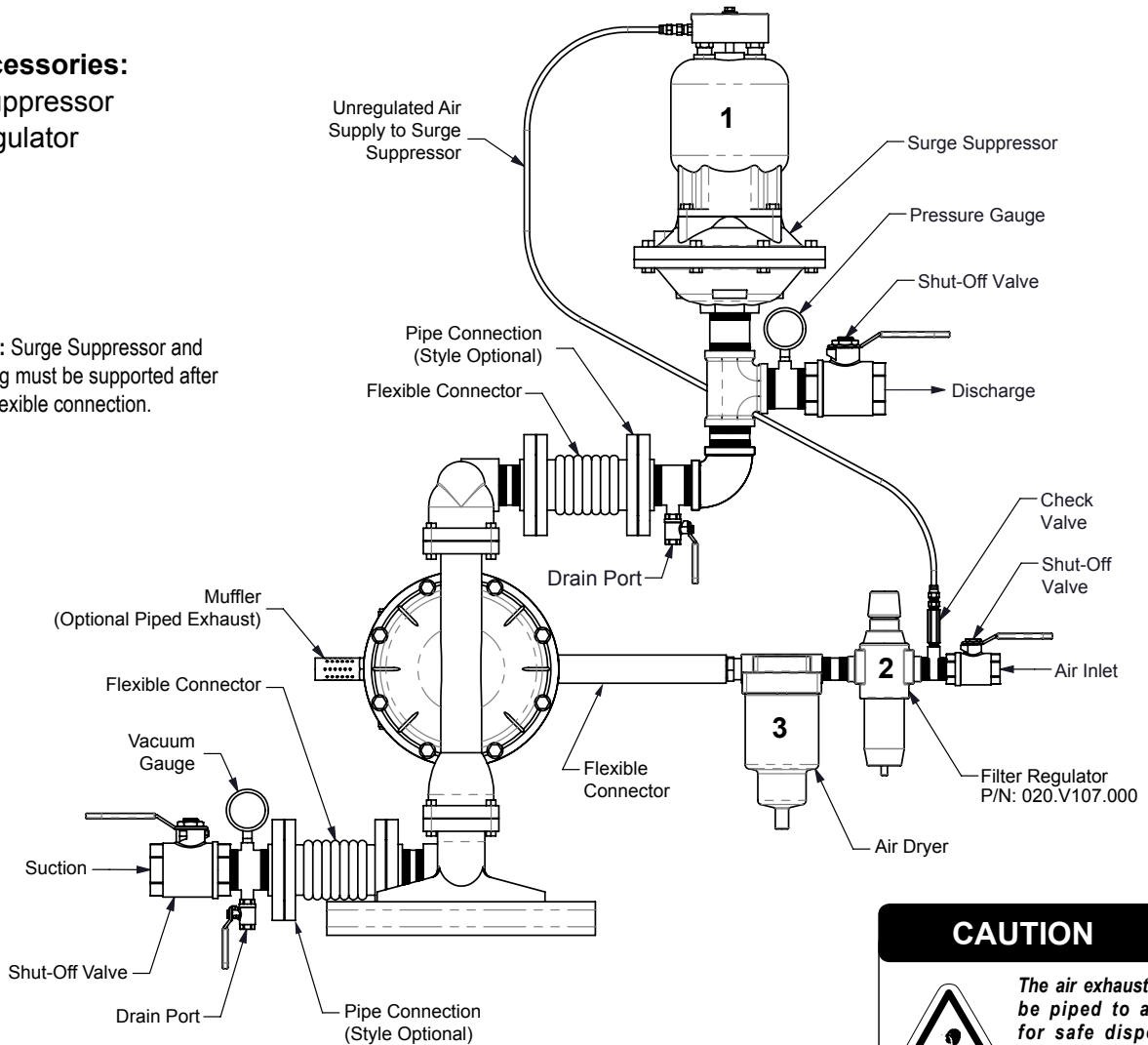

CAUTION



The air exhaust should be piped to an area for safe disposition of the product being pumped, in the event of a diaphragm failure.

Installation And Start-Up

Locate the pump as close to the product being pumped as possible. Keep the suction line length and number of fittings to a minimum. Do not reduce the suction line diameter.

Air Supply

Connect the pump air inlet to an air supply with sufficient capacity and pressure to achieve desired performance. A pressure regulating valve should be installed to insure air supply pressure does not exceed recommended limits.

Air Valve Lubrication

The air distribution system is designed to operate WITHOUT lubrication. This is the standard mode of operation. If lubrication is desired, install an air line lubricator set to deliver one drop of SAE 10 non-detergent oil for every 20 SCFM (9.4 liters/sec.) of air the pump consumes. Consult the Performance Curve to determine air consumption.

Air Line Moisture

Water in the compressed air supply may cause icing or freezing of the exhaust air, causing the pump to cycle erratically or stop operating. Water in the air supply can be reduced by using a point-of-use air dryer.

Air Inlet And Priming

To start the pump, slightly open the air shut-off valve. After the pump primes, the air valve can be opened to increase air flow as desired. If opening the valve increases cycling rate, but does not increase the rate of flow, cavitation has occurred. The valve should be closed slightly to obtain the most efficient air flow to pump flow ratio.

Troubleshooting Guide

Symptom:	Potential Cause(s):	Recommendation(s):
Pump Cycles Once	Deadhead (system pressure meets or exceeds air supply pressure).	Increase the inlet air pressure to the pump. Pump is designed for 1:1 pressure ratio at zero flow. (Does not apply to high pressure 2:1 units).
	Air valve or intermediate gaskets installed incorrectly.	Install gaskets with holes properly aligned.
	Bent or missing actuator plunger.	Remove pilot valve and inspect actuator plungers.
Pump Will Not Operate / Cycle	Pump is over lubricated.	Set lubricator on lowest possible setting or remove. Units are designed for lube free operation.
	Lack of air (line size, PSI, CFM).	Check the air line size and length, compressor capacity (HP vs. cfm required).
	Check air distribution system.	Disassemble and inspect main air distribution valve, pilot valve and pilot valve actuators.
	Discharge line is blocked or clogged manifolds.	Check for inadvertently closed discharge line valves. Clean discharge manifolds/piping.
	Deadhead (system pressure meets or exceeds air supply pressure).	Increase the inlet air pressure to the pump. Pump is designed for 1:1 pressure ratio at zero flow. (Does not apply to high pressure 2:1 units).
	Blocked air exhaust muffler.	Remove muffler screen, clean or de-ice, and re-install.
	Pumped fluid in air exhaust muffler.	Disassemble pump chambers. Inspect for diaphragm rupture or loose diaphragm plate assembly.
	Pump chamber is blocked.	Disassemble and inspect wetted chambers. Remove or flush any obstructions.
Pump Cycles and Will Not Prime or No Flow	Cavitation on suction side.	Check suction condition (move pump closer to product).
	Check valve obstructed. Valve ball(s) not seating properly or sticking.	Disassemble the wet end of the pump and manually dislodge obstruction in the check valve pocket. Clean out around valve ball cage and valve seat area. Replace valve ball or valve seat if damaged. Use heavier valve ball material.
	Valve ball(s) missing (pushed into chamber or manifold).	Worn valve ball or valve seat. Worn fingers in valve ball cage (replace part). Check Chemical Resistance Guide for compatibility.
	Valve ball(s)/seat(s) damaged or attacked by product.	Check Chemical Resistance Guide for compatibility.
	Check valve and/or seat is worn or needs adjusting.	Inspect check valves and seats for wear and proper setting. Replace if necessary.
	Suction line is blocked.	Remove or flush obstruction. Check and clear all suction screens or strainers.
	Excessive suction lift.	For lifts exceeding 20' of liquid, filling the chambers with liquid will prime the pump in most cases.
	Suction side air leakage or air in product.	Visually inspect all suction-side gaskets and pipe connections.
	Pumped fluid in air exhaust muffler.	Disassemble pump chambers. Inspect for diaphragm rupture or loose diaphragm plate assembly.
Pump Cycles Running Sluggish/Stalling, Flow Unsatisfactory	Over lubrication.	Set lubricator on lowest possible setting or remove. Units are designed for lube free operation.
	Icing.	Remove muffler screen, de-ice, and re-install. Install a point of use air drier.
	Clogged manifolds.	Clean manifolds to allow proper air flow
	Deadhead (system pressure meets or exceeds air supply pressure).	Increase the inlet air pressure to the pump. Pump is designed for 1:1 pressure ratio at zero flow. (Does not apply to high pressure 2:1 units).
	Cavitation on suction side.	Check suction (move pump closer to product).
	Lack of air (line size, PSI, CFM).	Check the air line size, length, compressor capacity.
	Excessive suction lift.	For lifts exceeding 20' of liquid, filling the chambers with liquid will prime the pump in most cases.
	Air supply pressure or volume exceeds system hd.	Decrease inlet air (press. and vol.) to the pump. Pump is cavitating the fluid by fast cycling.
	Undersized suction line.	Meet or exceed pump connections.
	Restrictive or undersized air line.	Install a larger air line and connection.
	Suction side air leakage or air in product.	Visually inspect all suction-side gaskets and pipe connections.
	Suction line is blocked.	Remove or flush obstruction. Check and clear all suction screens or strainers.
	Pumped fluid in air exhaust muffler.	Disassemble pump chambers. Inspect for diaphragm rupture or loose diaphragm plate assembly.
	Check valve obstructed.	Disassemble the wet end of the pump and manually dislodge obstruction in the check valve pocket.
	Check valve and/or seat is worn or needs adjusting.	Inspect check valves and seats for wear and proper setting. Replace if necessary.
Entrained air or vapor lock in chamber(s).	Purge chambers through tapped chamber vent plugs. Purging the chambers of air can be dangerous.	
Product Leaking Through Exhaust	Diaphragm failure, or diaphragm plates loose.	Replace diaphragms, check for damage and ensure diaphragm plates are tight.
	Diaphragm stretched around center hole or bolt holes.	Check for excessive inlet pressure or air pressure. Consult Chemical Resistance Chart for compatibility with products, cleaners, temperature limitations and lubrication.
Premature Diaphragm Failure	Cavitation.	Enlarge pipe diameter on suction side of pump.
	Excessive flooded suction pressure.	Move pump closer to product. Raise pump/place pump on top of tank to reduce inlet pressure. Install Back pressure device (Tech bulletin 41r). Add accumulation tank or pulsation dampener.
	Misapplication (chemical/physical incompatibility).	Consult Chemical Resistance Chart for compatibility with products, cleaners, temperature limitations and lubrication.
	Incorrect diaphragm plates or plates on backwards, installed incorrectly or worn.	Check Operating Manual to check for correct part and installation. Ensure outer plates have not been worn to a sharp edge.
Unbalanced Cycling	Excessive suction lift.	For lifts exceeding 20' of liquid, filling the chambers with liquid will prime the pump in most cases.
	Undersized suction line.	Meet or exceed pump connections.
	Pumped fluid in air exhaust muffler.	Disassemble pump chambers. Inspect for diaphragm rupture or loose diaphragm plate assembly.
	Suction side air leakage or air in product.	Visually inspect all suction-side gaskets and pipe connections.
	Check valve obstructed.	Disassemble the wet end of the pump and manually dislodge obstruction in the check valve pocket.
	Check valve and/or seat is worn or needs adjusting.	Inspect check valves and seats for wear and proper setting. Replace if necessary.
Entrained air or vapor lock in chamber(s).	Purge chambers through tapped chamber vent plugs.	

2: INSTAL & OP

For additional troubleshooting tips contact After Sales Support at service.warrenrupp@idexcorp.com or 419-524-8388

Composite Repair Parts Drawing - Elastomeric and TPE Fitted

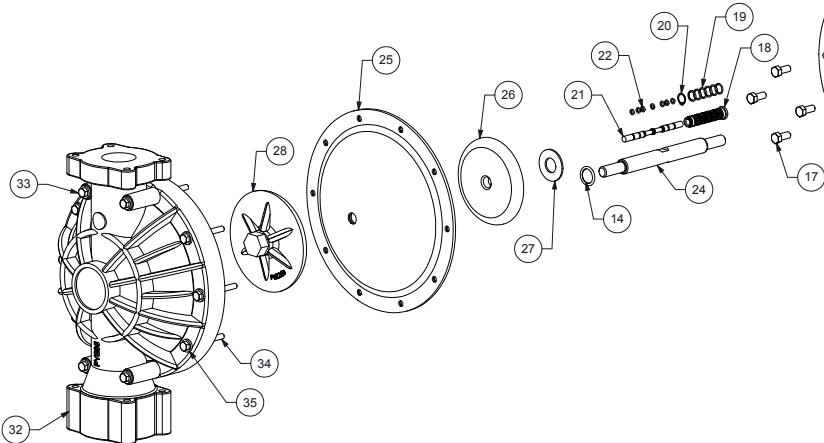
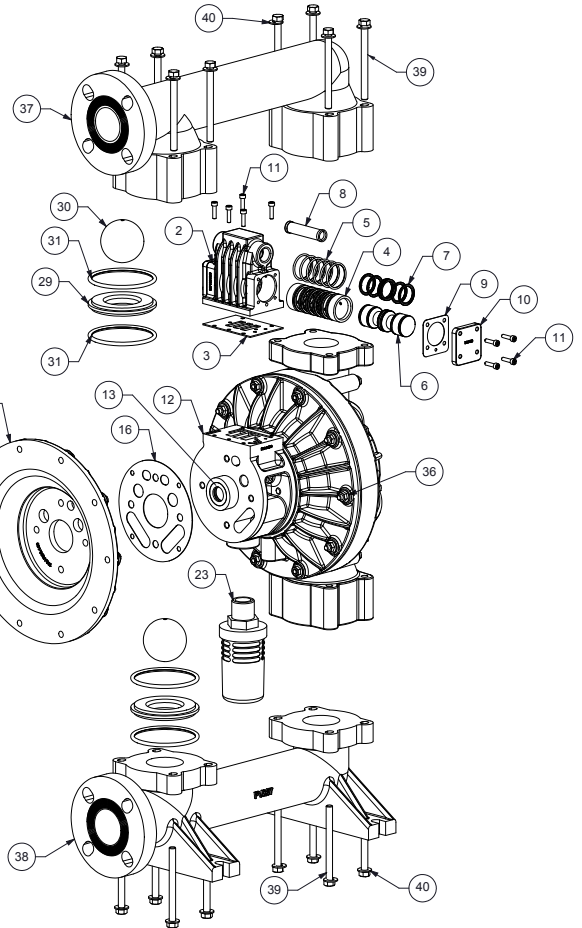
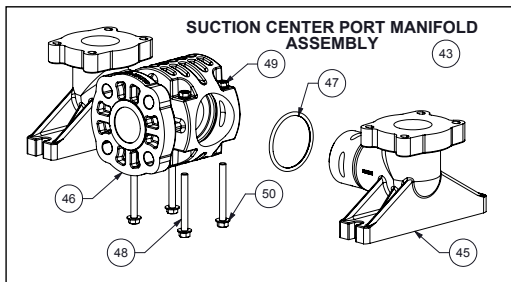
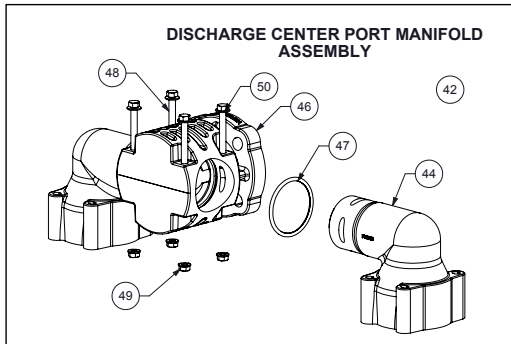

3: EXP VIEW

Composite Repair Parts List - Elastomeric and TPE Fitted

Air Valve Assembly						
Item #	Qty.	Description	Part Number			
			Aluminum	Stainless Steel	Nickel Plated	PTFE Coated
1	1	Valve Body (includes items 2-11)	031.V002.156	031.V002.110	031.V002.332	031.V002.309
2	1	Valve Body	095.V001.156	095.V001.110	095.V001.332	095.V001.309
3	1	Valve Body Gasket	P24-202			
4	1	Valve Sleeve	755.V006.148			
5	6	O-ring	560.206.360			
6	1	Valve Spool Assembly (Includes items 7)	775.V001.000			
7	6	Glyde Ring Assembly	P34-204F			
8	1	Air Valve Screen	P24-210	P34-210	P24-210	P24-210
9	2	End Cap Gasket	P24-205			
10	2	End Cap	P34-300	SP34-300		P34-300TC
11	13	Mounting Screws (8 included on item 1)	S1001			
Center Section Assembly						
Item #	Qty.	Description	Part Number			
			Aluminum	Stainless Steel	Nickel Plated	PTFE Coated
12	1	Center Block Assembly (Includes item 13 & 14)	P24-400DC ASY	SP24-400	P24-401NP	P24-401TC
13	2	Bearing Sleeve	P31-403			
14	2	Main Shaft O-Ring	P24-403			
15	2	Air Chamber	196.V003.156	196.V003.110	196.V003.332	196.V003.309
16	2	Air Chamber Gasket	360.V001.360	P24-109A	360.V001.360	
17	8	Bolt	P24-110	SP24-110		
18	1	Pilot Sleeve Assembly (include item 19)	755.V002.000			
19	6	O-ring	560.101.358			
20	1	Retaining Ring	675.037.080			
21	1	Pilot Spool Assembly (Includes item 22)	775.V002.000			
22	8	O-ring	560.023.358			
23	1	Muffler	VTM-8			
Diaphragm Assembly / Elastomers						
Item #	Qty.	Description	Part Number			
			Polypropylene		PVDF	
24	1	Main Shaft	P24-103			
25	2	Diaphragm (See Below Material Chart)	V227xx			
26	2	Inner Diaphragm Plate (See Note 3)	V226B, V226BNP, V226BTC, SV226B			
27	2	Bumper Washer	P24-501			
28	2	Outer Diaphragm Plate (See Note 1 Below)	PV226B	KV226B		
29	4	Valve Seat	PV240	KV240		
30	4	Valve Ball (See Below Material Chart)	V241xx			
31	8	Valve Seat O-Ring (See Below Material Chart)	V258xx			
Wet End Assembly						
Item #	Qty.	Description	Part Number			
			Polypropylene		PVDF	
32	2	Water Chamber	PV235			
33	8	Large Bolt	SV250B			
34	12	Small Bolt	SV250A			
35	20	Washer	SV250C			
36	20	Nut	SV185B			
37	1	Discharge Manifold	PV236	KV236		
38	1	Suction Manifold	PV237	KV237		
39	16	Manifold Bolt	SV251A			
40	16	Washer	SV302GA			
41	16	Nut	SV251B			
Optional Center Port Manifold Assembly						
Item #	Qty.	Description	Part Number			
			Polypropylene		PVDF	
42	1	Discharge Manifold ASY (includes items 43 & 45-49)	PV236CP			
43	1	Suction Manifold ASY (includes items 42 & 45-49)	PV237CP			
44	2	Discharge Elbow	PV236E			
45	2	Suction Elbow	PV237E			
46	2	Manifold Tee	PV288			
47	4	Manifold Tee O-Ring (See Note 2)	V288TES, V258XL			
48	8	Bolt	SV288B			
49	8	Nut	SV251B			
50	8	Washer	SV302GA			
Elastomer Material Specifications						
Material	Diaphragm P/N		Valve Ball P/N		Seat O-Ring P/N	
Neoprene	V227N		V241N		N/A	
Nitrile	V227BN		V241BN		V258BN	
FKM	V227VT		V241VT		V258VT	
EPDM	V227ND		V241ND		V258ND	
PTFE	N/A		V241TF		V258TES	
Santoprene	V227TPEXL		V241TPEXL		V258XL	
Hytrel	V227TPEFG		V241TPEFG		N/A	
Geolast	N/A		V241G		N/A	

Notes:

- 1.) The inner diaphragm plate is to match the inner chamber material (Ref. Note 3)
- 2.) TES = PTFE Encapsulated Silicone, XL = Santoprene
- 3.) V = Aluminum, TC = PTFE Coated, NP = Nickel Plated, SV = Stainless Steel



3: EXP VIEW

Composite Repair Parts Drawing - PTFE Fitted

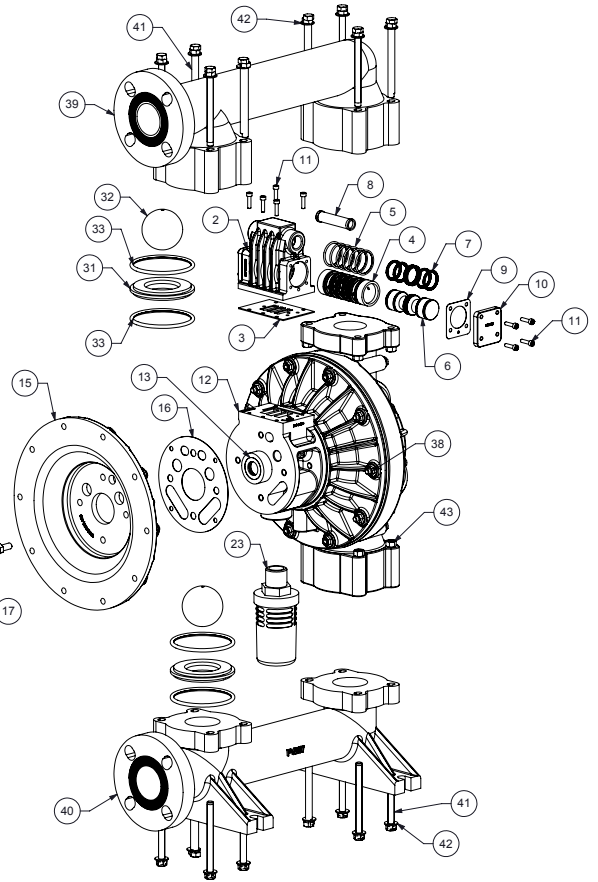
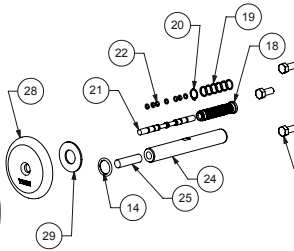
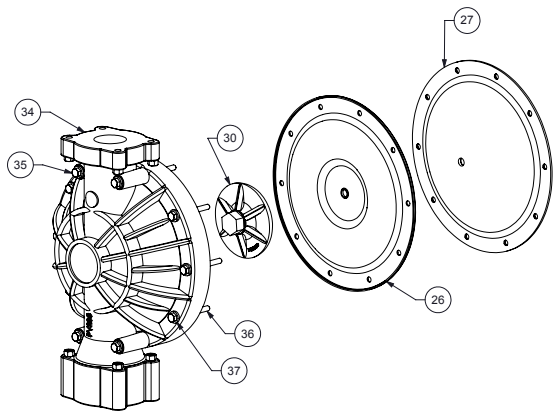
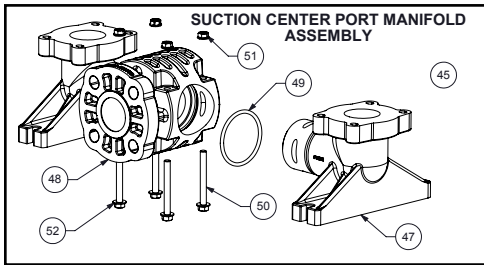
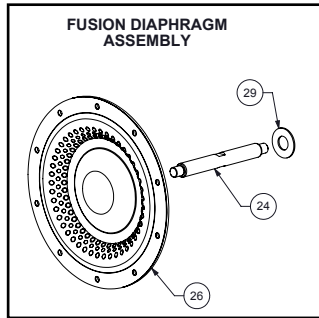
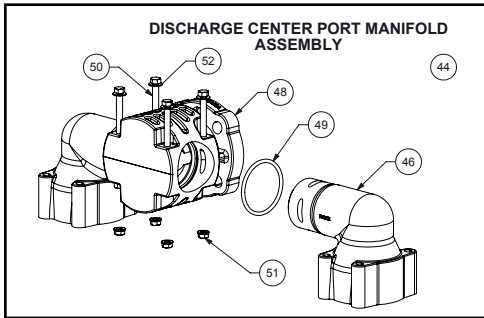

3: EXP VIEW

Composite Repair Parts List - PTFE Fitted

Air Valve Assembly						
Item #	Qty.	Description	Part Number			
			Aluminum	Stainless Steel	Nickle Plated	PTFE Coated
1	1	Valve Body (includes items 2-11)	031.V002.156	031.V002.110	031.V002.332	031.V002.309
2	1	Valve Body	095.V001.156	095.V001.110	095.V001.332	095.V001.309
3	1	Valve Body Gasket	P24-202			
4	1	Valve Sleeve	755.V006.148			
5	6	O-ring	560.206.360			
6	1	Valve Spool Assembly (Includes items 7)	775.V001.000			
7	6	Glyde Ring Assembly	P34-204F			
8	1	Air Valve Screen	P24-210	P34-210	P24-210	P24-210
9	2	End Cap Gasket	P24-205			
10	2	End Cap	P34-300	SP34-300	P34-300TC	
11	13	Mounting Screws (8 included on item 1)	S1001			
Center Section Assembly						
Item #	Qty.	Description	Part Number			
			Aluminum	Stainless Steel	Nickle Plated	PTFE Coated
12	1	Center Block Assembly (Includes item 13 & 14)	P24-400DC ASY	SP24-400	P24-401NP	P24-401TC
13	2	Bearing Sleeve	P31-403			
14	2	Main Shaft O-Ring	P24-403			
15	2	Air Chamber	196.V003.156	196.V003.110	196.V003.332	196.V003.309
16	2	Air Chamber Gasket	360.V001.360	P24-109A	360.V001.360	
17	8	Bolt	P24-110	SP24-110		
18	1	Pilot Sleeve Assembly (include item 19)	755.V002.000			
19	6	O-ring	560.101.358			
20	1	Retaining Ring	675.037.080			
21	1	Pilot Spool Assembly (Includes item 22)	775.V002.000			
22	8	O-ring	560.023.358			
23	1	Muffler	VTM-8			
Diaphragm Assembly / Elastomers						
Item #	Qty.	Description	Part Number			
			PTFE Two Peice		Fusion	
			Polyproylene	PVDF	Polyproylene	PVDF
24	1	Main Shaft	P24-102		P24-103F	
25	2	Shaft Stud	V221F			
26	2	Diaphragm	V227TF			
27	2	Back-Up Diaphragm	V227TFB			
28	2	Inner Diaphragm Plate	V221TI,V221TINP, V221TITC, SV221TI			
29	2	Bumper Washer	P24-501			
30	2	Outer Diaphragm Plate	PV221TO	KV221TO	N/A	
31	4	Valve Seat	PV240	KV240	PV240	KV240
32	4	Valve Ball	V241TF			
33	8	Valve Seat O-Ring	V258TES			
Wet End Assembly						
Item #	Qty.	Description	Part Number			
			Polyproylene		PVDF	
34	2	Water Chamber	PV235		KV235	
35	8	Large Bolt	SV250B			
36	12	Small Bolt	SV250A			
37	20	Washer	SV250C			
38	20	Nut	SV185B			
39	1	Discharge Manifold	PV236	KV236		
40	1	Suction Manifold	PV237	KV237		
41	16	Manifold Bolt	SV251A			
42	16	Washer	SV302GA			
43	16	Nut	SV251B			
Optional Center Port Manifold Assembly						
Item #	Qty.	Description	Part Number			
			Polyproylene		PVDF	
44	1	Discharge Manifold ASY (includes items 46 & 48-52)	PV236CP		KV236CP	
45	1	Suction Manifold ASY (includes items 47 & 48-52)	PV237CP		KV237CP	
46	2	Discharge Elbow	PV236E		KV236E	
47	2	Suction Elbow	PV237E		KV237E	
48	2	Manifold Tee	PV288		KV288	
49	4	Manifold Tee O-Ring	V288TES, V258XL			
50	8	Bolt	SV288B			
51	8	Nut	SV251B			
52	8	Washer	SV302GA			

Notes:

- 1.) The inner diaphragm plate is to match the inner chamber material
V = Aluminum, TC = PTFE Coated, NP = Nickel Plated, SV = Stainless Steel

3: EXP VIEW

Written Warranty

5 - YEAR Limited Product Warranty

Quality System ISO9001 Certified • Environmental Management Systems ISO14001 Certified

Versa-Matic warrants to the original end-use purchaser that no product sold by Versa-Matic that bears a Versa-Matic brand shall fail under normal use and service due to a defect in material or workmanship within five years from the date of shipment from Versa-Matic's factory.

~ See complete warranty at <http://www.versamatic.com/pdfs/VM%20Product%20Warranty.pdf> ~

DECLARATION OF CONFORMITY

DECLARATION DE CONFORMITE • DECLARACION DE CONFORMIDAD • ERKLÄRUNG BEZÜGLICH EINHALTUNG DER VORSCHRIFTEN
DICHIARAZIONE DI CONFORMITÀ • CONFORMITEITSVERKLARING • DEKLARATION OM ÖVERENSSTÄMMELSE
EF-OVERENSSTEMMELSESERKLÆRING • VAATIMUSTENMUKAISUUSVAKUUTUS • SAMSVARSERKLÄRING
DECLARAÇÃO DE CONFORMIDADE

MANUFACTURED BY:

FABRIQUE PAR:
FABRICADA POR:
HERGESTELLT VON:
FABBRICATO DA:
VERVAARDIGD DOOR:
TILLVERKAD AV:
FABRIKANT:
VALMISTAJA:
PRODUSENT:
FABRICANTE:

VERSA-MATIC®
Warren Rupp, Inc.
A Unit of IDEX Corporation
800 North Main Street
P.O. Box 1568
Mansfield, OH 44901-1568 USA
Tel: 419-526-7296
Fax: 419-526-7289



PUMP MODEL SERIES: E SERIES, V SERIES, VT SERIES, VSMA3, SPA15, RE SERIES AND U2 SERIES

This product complies with the following European Community Directives:

Ce produit est conforme aux directives de la Communauté européenne suivantes:
Este producto cumple con las siguientes Directrices de la Comunidad Europea:
Dieses produkt erfüllt die folgenden Vorschriften der Europäischen Gemeinschaft:
Questo prodotto è conforme alle seguenti direttive CEE:
Dir produkt voldoet aan de volgende EG-richtlijnen:
Denna produkt överensstämmer med följande EU direktiv:
Versa-Matic, Inc., erklærer herved som fabrikant, at ovennævnte produkt er i overensstemmelse med bestemmelserne i Direktive:
Tämä tuote täyttää seuraavien EC Direktiivien vaatimukset:
Dette produkt oppfyller kravene til følgende EC Direktiver:
Este produto está de acordo com as seguintes Directivas comunitárias:

2006/42/EC
on Machinery, according
to Annex VIII

This product has used the following harmonized standards to verify conformance:

Ce matériel est fabriqué selon les normes harmonisées suivantes, afin d' en garantir la conformité:
Este producto cumple con las siguientes directrices de la comunidad europea:
Dieses produkt ist nach folgenden harmonisierten standards gefertigt worden, die übereinstimmung wird bestätigt:
Questo prodotto ha utilizzato i seguenti standards per verificare la conformità:
De volgende geharmoniseerde normen werden gehanteerd om de conformiteit van dit produkt te garanderen:
För denna produkt har följande harmoniserande standarder använts för att bekräfta överensstämmelse:
Harmoniserede standarder, der er benyttet:
Tässä tuotteessa on sovellettu seuraavia yhdenmukaistettuja standardeja:
Dette produkt er produsert i overensstemmelse med følgende harmoniserte standarder:
Este produto utilizou os seguintes padrões harmonizados para verificar conformidade:

EN809:1998+
A1:2009

AUTHORIZED/APPROVED BY:

Approuve par:
Aprobado por:
Genehmigt von:
approvato da:
Goedgekeurd door:
Underskrift:
Valtuutettuna:
Bemyndiget av:
Autorizado Por:

Dave Roseberry
Engineering Manager

DATE: August 10, 2011

FECHA:
DATUM:
DATA:
DATO:
PÄIVÄYS:



VMQR 044FM

04/19/2012 REV 07