

# *Air Operated Double Diaphragm Pump*

---

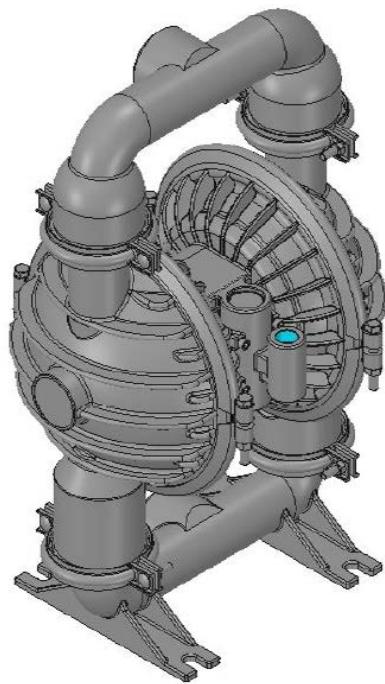

**M-Pump 2”**

**Metallic Clamp  
Band**

**INSTALLATION,  
OPERATION &  
MAINTENANCE  
MANUAL**

# INDEX

<u>Title</u>	<u>Section</u>
<i>Introduction</i>	<i>.1</i>
<i>Safety</i>	<i>.2</i>
<i>Warranty, General Terms &amp; Conditions</i>	<i>.3</i>
<i>Dimensions</i>	<i>.4</i>
<i>Performance Curve</i>	<i>.5</i>
<i>Technical Data</i>	<i>.6</i>
<i>Installation &amp; Maintenance</i>	<i>.7</i>
<i>Trouble Shooting</i>	<i>.8</i>
<i>Exploded View and Spare Part List</i>	<i>.9</i>
<i>Service and Maintenance Log</i>	<i>.10</i>

# 1. Introduction

---

This manual provides instruction for the installation, operation and maintenance of your M-Pump.

**IT IS ESSENTIAL THAT THIS MANUAL IS READ AND UNDERSTOOD BY ALL PERSONS INSTALLING, OPERATING AND / OR MAINTAINING THE PUMP.**

The M-PUMP meets or exceeds International standards for A.O.D pumps, is well proven, reliable and safe when correctly installed and operated in accordance with this manual.

In case of doubt or enquiries, please contact our Technical Service dept.: [info@m-pump.net](mailto:info@m-pump.net)

## 2. Safety

---

### 2.1 General

This manual contains the information needed for the correct installation, use and maintenance of your M-Pump. This manual must be kept with, and supplied with the pump at all times. Failure to comply with the recommendations stated in this manual can cause serious injury, damage the pump and void factory warranty.

### 2.2 Operator Qualification and Training

The personnel in charge of the installation, operation, and the maintenance of the pump must be suitably qualified and able to perform the operations described in this manual.

M-Pump shall not be held responsible for the use of untrained personnel and, or those not fully aware of the contents of this manual.

As a customer service, M-Pump offer training programs associated with M-Pump products. For further information and cost, please contact our Technical Services team at:

[info@m-pump.net](mailto:info@m-pump.net)

### 2.3 Safety Instructions

#### 2.3.2 for your own safety

BEFORE using or servicing your pump, please make sure to wear the proper clothing, eye protection and follow standard safety procedures when handling corrosive or personally harmful materials.

To avoid danger and risk to yourself and others always use only genuine M-Pump parts.

#### 2.3.2 warning

Fire or explosion can result when handling flammable liquids. The pump, piping, valves, containers or other miscellaneous equipment must be grounded.

When used for toxic or aggressive fluids, the pump should always be flushed clean prior to disassembly. User must ensure chemical compatibility, and any pressure / temperature limits are not exceeded.

NB: Temperature and pressure limits for diaphragms and other components are noted in the technical section of this manual.

### **2.3.3** **caution**

**2.3.3.1** The pump is pressurized internally with air during operation. Before commencing any work or maintenance on the M-Pump, shut off the compressed air line, safely bleed the pressure, and disconnect the air-line from the pump. The product discharge line may be pressurized and must be safely bled off its pressure. Never place your hands near the suction inlet as the powerful suction can cause serious bodily injury.

**2.3.3.2** If the pump is not used for more than two (2) days, care must be taken when restarting. If in any doubt, remove pump from line and flush with a suitable cleaner. Solidified deposits within the pump may cause damage to the diaphragms.

**2.3.3.3** Before starting or resuming pump operation after maintenance, inspect all fasteners are correct, check for looseness caused by gasket creep. Re-torque all fasteners to prevent leakage. Follow recommended torques stated in this manual.

Ensure correct fitting of Inlet / Outlet connections. Crossed threads or over tightening of connections will result in leaks.

Quick action/release connections are not recommended. If their use is unavoidable, the levers must be locked to avoid them being forced apart in a hazardous manner.

In case of excess vibration, M-Pump recommend fitting a Pulsation Dampener to remove effects of pulse actions from pump operation. Flexible connections can be used, but must be kept to a minimum length necessary to avoid sharp flexing or straining movements.

## **3. Limited Warranty, General Terms & Conditions**

---

Every M-Pump is manufactured to meet the highest standards of quality. Every pump is functionally tested to ensure integrity of operation. M-Pump warrants that pumps, accessories and parts manufactured by M-Pump to be free from defects in material and workmanship for a period of twelve (12) months from date of installation or eighteen (18) months from date of manufacture, whichever comes first. Products, parts or accessories manufactured by others but supplied by M-Pump are covered only to the extent of the original manufacturers warranty for replacement or repair.

Failure due to normal wear and tear, improper storage or handling, un-authorized modification, misapplication or abuse is specifically excluded from this warranty. M-Pump shall not be liable for any and all consequential damage or expense arising from the use or misuse of its products. In any and all events, manufacturer's liability shall not exceed the purchase price of the product and/or accessories. All decisions as to the cause of failure are the sole determination of M-Pump.

***THE WARRANTY / LIABILITY AS SET FORTH ARE EXCLUSIVE AND IN LIEU OF ALL OTHER WARRANTIES AND LIABILITIES EXPRESSED OR IMPLIED, INCLUDING WARRANTY OF MERCHANTABILITY AND FITNESS FOR PURPOSE.***

## 4. Dimensions

# Aluminium

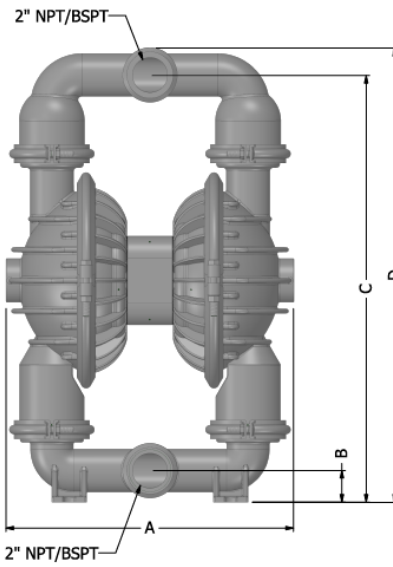
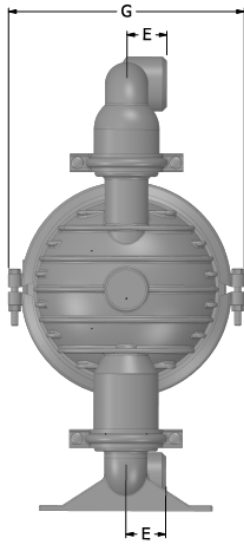

ITEM	METRIC (mm)	STANDARD (INCH)
A	422	16.6
B	46	1.8
C	625.5	24.6
D	665.4	26.2
E	58.5	2.3
F	58.5	2.3
G	346	13.6
H	121.5	11.3
J	237	9.3
K	254	10
L	216	8.5
M	16	0.6

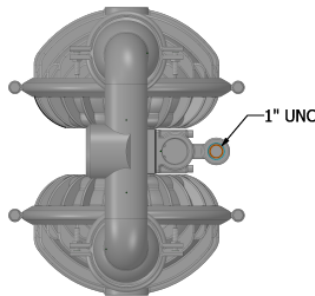
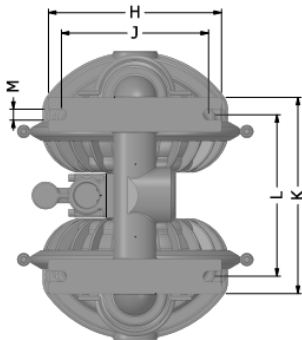

## 5. *Performance Curve*

---

## 6. Technical Data and Code

General Limits for standard pumps.

NB: Special designs are available on request

<b>Maximum Flow (Liters per minute)</b>	<b>Maximum Solids Diameter (mm)</b>	Metallic Fluid Connections 2" (BSP / NPT)	<b>Maximum Working Pressure (psi)</b>
650	6		125
<b>Maximum Lift (Dry)</b>	<b>Air Inlet Connection</b>	Non Metallic Fluid Connections 2" (ANSI / DIN) Flange	<b>Temperature limits</b>
6m	¾" NPT (F)		Determined by Elastomers

### Typical Pump Design Code



Series	Pump Sizes	Wet Parts	Non Wet Parts	Diaphragm	Ball Valve	Valve Seat	Connections
MP: Clamp Design MB: Bolt design	0.25: ¼" 0.5: ½" 1: 1" 1.5: 1.5" 2: 2" 3: 3"	A: Aluminium P: Polypropylene K: Kynar S: Stainless Steel	A: Aluminium G: GFPP  <b>Optional</b> S: Stainless Steel	B: Buna-N E: EPDM H: Hytrel N: Neoprene T: PTFE U: Polyurethane V: Viton W: Santoprene	B: Buna-N E: EPDM H: Hytrel N: Neoprene T: PTFE U: Polyurethane V: Viton W: Santoprene	A: Aluminium B: Buna-N K: Kynar N: Neoprene P: Polypropylene S: Stainless Steel T: PTFE W: Santoprene	BSP: BSP Thread F: Flange NPT: NPT Thread

## Elastmoers Service Guideline

<b>Compound</b>	<b>Optimum Temperature</b>	<b>Main Applications / Chemical Compatibility</b>
Neoprene	10 to 54°C	General purpose diaphragm (non-aggressive applications -- water-based slurries, well water or sea water)
	50 to 130°F	
Buna-N	10 to 60°C	Petroleum/oil-based fluids (leaded gasoline, fuel oils, non-synthetic hydraulic oils, kerosene, turpentine, motor oils)
	50 to 140°F	
EPDM	10 to 60°C	Extremely cold temperatures. Low cost alternative when pumping dilute acids or caustics.
	50 to 140°F	
Viton	24 to 100°C	Extremely hot temperatures. Aggressive fluids such as aromatic or chlorinated hydrocarbons and highly aggressive acids in applications involving suction lift outside the range of PTFE
	75 to 212°F	
Polyurethane	10 to 54°C	Non-aggressive applications (water-based slurries, well water or sea water)
	50 to 130°F	
Santoprene	10 to 100°C	Low cost alternative to Teflon® in many acidic and caustic applications such as sodium hydroxide, sulfuric or hydrochloric, At a cost comparable to neoprene.
	50 to 212°F	
Hytrel	10 to 54°C	FDA approved for food processing applications. Outstanding general purpose diaphragm as well.
	50 to 130°F	
PTFE	10 to 100°C	Aggressive chemicals and solvent but low abrasion resistance



## 7. Installation & Maintenance Instructions

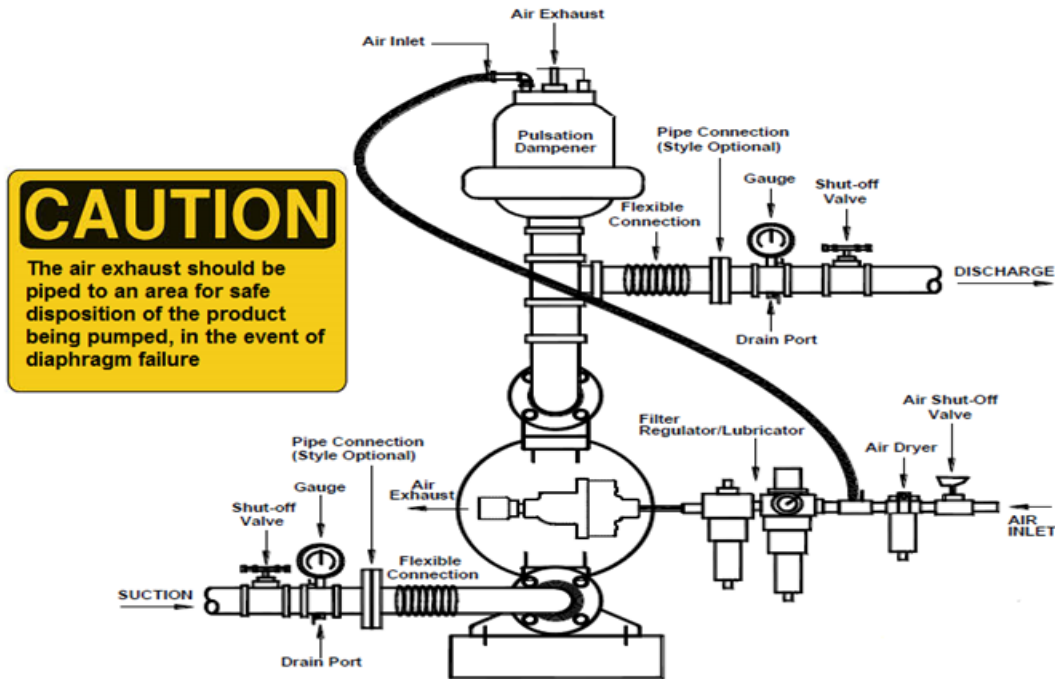

### Suggest Diaphragm Pump Installation diagram

#### Installation

- i. Remove the diaphragm pump from the packaging and inspect for shipping damage.
- ii. Pumps are tested in water at assembly. Flush pump with compatible fluid prior to installation.
- iii. Your installation will depend on the type of fluid being pumped and your application needs. To reduce the risk of serious bodily injury and damage to property, never use fluids, in this pump, which are not compatible with the wetted components. Contact your local distributor or the manufacturer for system design assistance & compatibility if necessary.
- iv. Mount the pump in an upright position. Failure to ensure an upright position may result in loss of or poor priming characteristics. Ensure the pump is securely mounted to avoid movement and possible risk of bodily injury.
- v. Material supply tubing should be at least the same diameter as the pump suction and discharge connection.

#### Maintenance

**Caution:** Before commencing any service or maintenance work on the pump, ensure that the air supply has been disconnected or isolated and all air pressure allowed to bleed from the pump. Before disconnecting suction and discharge piping, ensure suction and discharge valves are closed and discharge line is bled of its pressure. Drain the pump into suitable container. Beware of any hazardous materials and always follow the MSDS for your process fluid.

## Disassembly

- **Air valve system**
  - a. Remove Air valve casing, air valve gasket, and Side valve plate.
  - b. Tap to remove Slide valve.
  - c. Remove End caps to release Valve carrier.
  
- **Wet section**
  - a. Remove Discharge manifold and Suction manifold.
  - b. Remove balls; "O" rings (if applicable) and seats.
  - c. Remove Outer chamber.
  - d. Remove the Outer piston plate.

## Inspections

- **Air valve system**
  - a. The Slide valve and Slide valve plate contact faces should be flat and free from scratches. A light polishing on a flat surface with a fine abrasive paper will remove most scratches.
  - b. Clean the Air valve casing and Valve carrier; remove any oil films.
  
- **Wet section**
  - a. Check for corrosion of Bolts and Washers.
  - b. Check for corrosion of Outer chambers.
  - c. Check for rupture of Diaphragms.
  - d. Check the shape of the ball and damage on the seats.
  - e. Check for Shaft wear and PU O-Ring for ID Bushing.

## Assembly

NB: Before assembly - all Seals must be replaced and all replaced parts must be new OEM parts

- **Air valve system**
  - a. Reassemble the Valve carrier to Valve Casing
  - b. Apply light grease on the valve casing and end cap, when re-assembling. Any damage to the O-ring may cause the valve system to malfunction.
  - c. Assemble Slide valve and Slide valve plate.
  - d. Replace with New Air Valve Gaskets
  - e. Reassemble Valve Casing & re-torque in accordance to the setting shown in parts list.
  
- **Wet section**
  - a. Clean and inspect all parts. Replace worn or damaged parts with new parts as required
  - b. Reassemble in reverse order.
  - c. Re-torque in accordance to the setting shown in parts list
  - d. Lubricate bushing and shaft with SAE 10 lubrication oil or better
  - e. Torque Bolts. Torque should be rechecked after pump has run a while (approx. 1hr)

## 8. Trouble Shooting



Problem	Cause	Solution
Pump cannot start	<ul style="list-style-type: none"> <li>➤ Air connected to Exhaust</li> <li>➤ Discharge piping obstructed or shut off valve closed.</li> <li>➤ Shaft Seal failure</li> <li>➤ Diaphragm ruptured</li> <li>➤ Air Valve System malfunction</li> </ul>	<ul style="list-style-type: none"> <li>➤ Re-connect to Air Inlet</li> <li>➤ Clean the line or open the shut off valve</li> <li>➤ Replace New Shaft Seal</li> <li>➤ Replace Diaphragm</li> <li>➤ Check carrier for freedom of movement and all seals in chest assembly. Clean or replace.</li> </ul>
Pump runs but no discharge	<ul style="list-style-type: none"> <li>➤ Suction Line Leakage</li> <li>➤ Valve ball not seating correctly or damaged</li> <li>➤ Suction Strainer or Line clogged</li> <li>➤ Excessive Suction Lift</li> <li>➤ Diaphragm ruptured</li> </ul>	<ul style="list-style-type: none"> <li>➤ Check and Repair</li> <li>➤ Remove obstruction / replace balls or seats</li> <li>➤ Clear</li> <li>➤ Shorten Suction line</li> <li>➤ Replace Diaphragm</li> </ul>
Intermittent stroke rate	<ul style="list-style-type: none"> <li>➤ Shaft Seal failure</li> <li>➤ Air Valve System malfunction</li>   <li>➤ Over lubrication</li> <li>➤ Valve Ball obstruction or not sealing</li> </ul>	<ul style="list-style-type: none"> <li>➤ Replace New Shaft Seal</li> <li>➤ Check carrier for freedom of movement and all seals in chest assembly. Clean or replace.</li> <li>➤ Clean the Air Valve System &amp; Shaft bushing.</li> <li>➤ Remove obstruction / replace balls or seats</li> </ul>
Fluid discharge from air exhaust	<ul style="list-style-type: none"> <li>➤ Loose Outer Piston</li> <li>➤ Diaphragm ruptured</li> </ul>	<ul style="list-style-type: none"> <li>➤ Re-Torque to manual specification</li> <li>➤ Replace Diaphragm</li> </ul>
Erratic Flow	<ul style="list-style-type: none"> <li>➤ Diaphragm ruptured one side</li> <li>➤ Suction Line Leakage</li> <li>➤ Air Valve System malfunction</li>   <li>➤ Shaft Seal failure</li> <li>➤ Valve ball not seating correctly or damaged</li> </ul>	<ul style="list-style-type: none"> <li>➤ Replace Diaphragm</li> <li>➤ Check &amp; Repair</li> <li>➤ Check carrier for freedom of movement and all seals in chest assembly. Clean or replace.</li> <li>➤ Replace New Shaft Seal</li> <li>➤ Remove obstruction / replace balls or seats</li> </ul>

# 9. Exploded View

## M-Pumps (Aluminum Clamp Band Series)

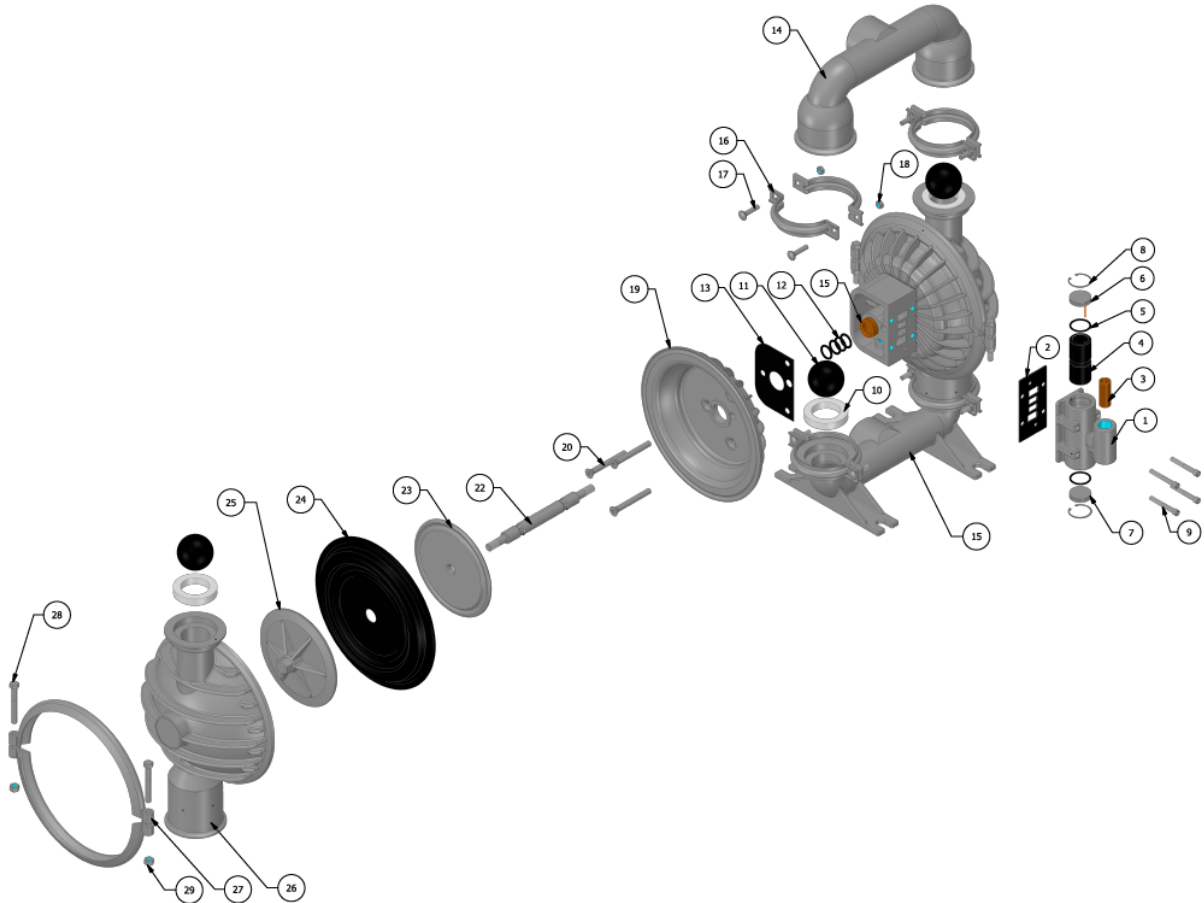

## Spare Parts List

ITEM NO.	PART NUMBER	DESCRIPTION	QTY
1	PNSV501BR	AIR VALVE BODY	1
2	PNSG581VF	AIR VALVE GASKET	1
3	PNSV503SB	AIR VALVE SCREEN	1
4	PNSVPN	PISTON	1
5	PNSF519BN	AIR VALVE CAP O-RING	2
6	PNSV504BR	AIR VALVE CAP (TOP)	1
7	PNSV505BR	AIR VALVE CAP (BOTTOM)	1
8	PNSH561MS	AIR VALVE SNAP RING	2
9	PNSH560MS	AIR VALVE SCREW	4
10	SEE TABLE	VALVE SEAT	4
11	SEE TABLE	SOLID BALL	4
12	PNDF520BC	AIR SECTION BUSHING O-RING	4
13	PNSG582VF	AIR SECTION GASKET	2
14	PNSC538AL	DISCHARGE MANIFOLD	1
15	PNSH587BR	AIR SECTION BUSHING	1
16	PNSH555MS	SMALL CLAMP BAND	8
17	PNSH556MS	SMALL CLAMP BAND BOLT	8
18	PNSH557MS	SMALL CLAMP BAND NUT	8
19	PNSC537AL	AIR CHAMBER	2
20	PNSH565MS	AIR CHAMBER SCREW	3
21	PNSH566MS	AIR CHAMBER NUT	3
22	PNSH562SS	MAIN SHAFT	1
23	PNSC532AL	INNER PISTON	2
24	SEE TABLE	DIAPHARGM	2
25	PNSC533AL	OUTER PISTON	2
26	PNSC537AL	LIQUID CHAMBER	2
27	PNSH551MS	LARGE CLAMP BAND	4
28	PNSH552MS	LARGE CLAMP BAND BOLT	4
29	PNSH553MS	LARGE CLAMP BAND NUT	4

ITEM NO.	PART NUMBER	DESCRIPTION	QTY
10. VALVE SEAT			
10.1	PNSF514NE	NEOPRENE VALVE SEAT	4
10.2	PNSF514BN	BUNA-N VALVE SEAT	4
11. SOLID BALL			
11.1	PNSF513NE	NEOPRENE SOLID BALL	4
11.2	PNSF513BN	BUNA-N SOLID BALL	4
24. DIAPHARGM			
24.1	PNSF511NE	NEOPRENE DIAPHARGM	2
24.2	PNSF511NE	BUNA-N DIAPHARGM	2

