

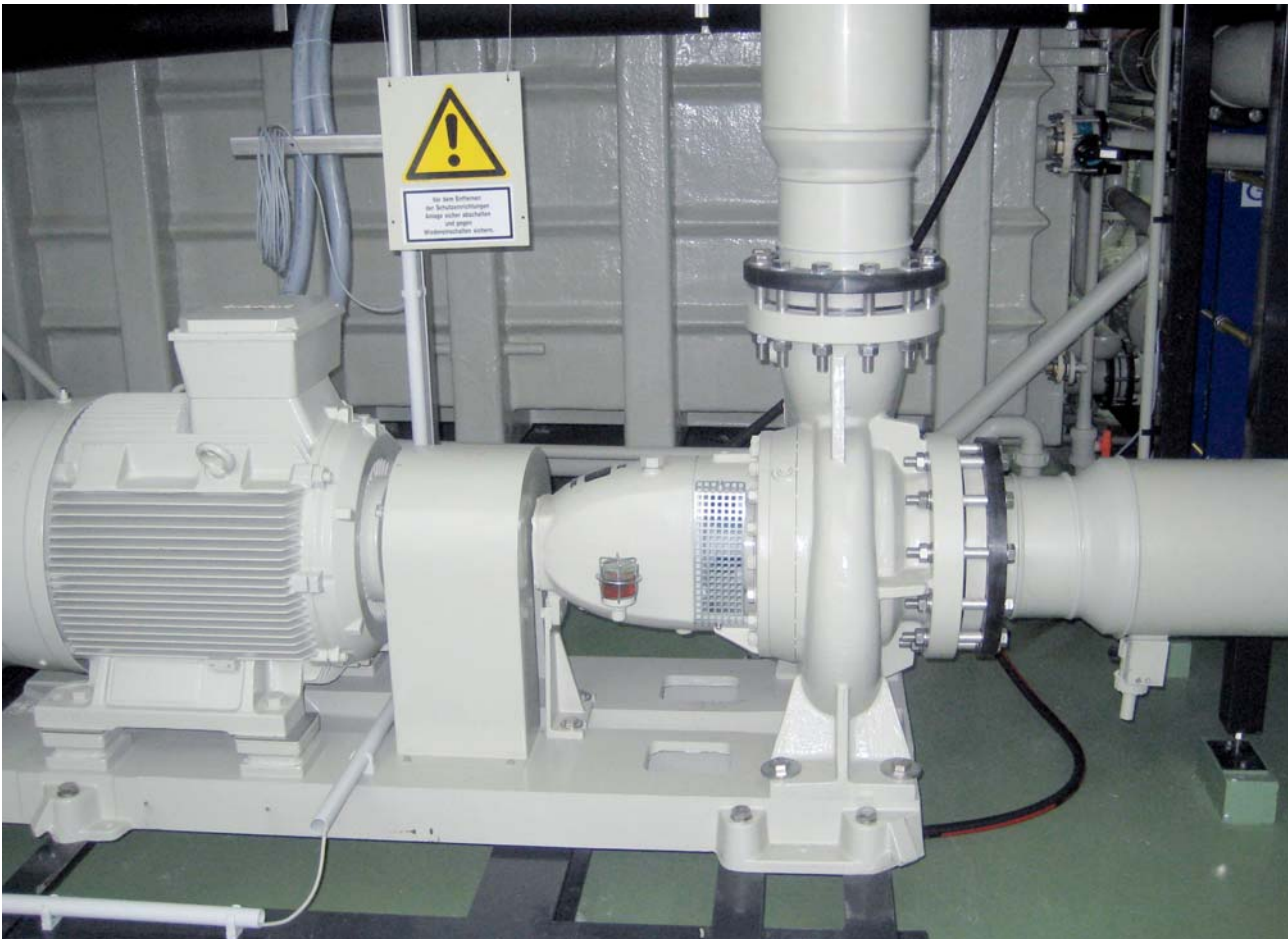

**DICKOW
PUMPEN**

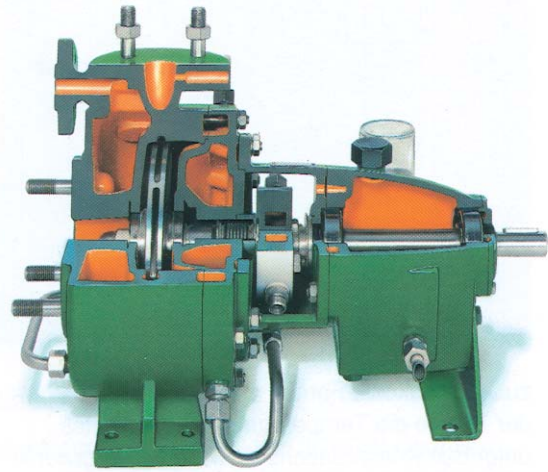

**Centrifugal Pumps
acc. to EN 22858 / ISO 2858
with Shaft Sealing**

Type NCL

General

The DICKOW centrifugal pump acc. to EN 22858 / ISO 2858 is designed for handling liquids in the chemical and petrochemical industry, in refineries, for heat transfer liquids ect.

Dimensions and performance range are developed in accordance to EN 22858 (ISO 2858). The whole range is so subdivided that for all service conditions the best efficiency is guaranteed. The maximum capacity goes up to 900 m³/h or 3960 US gpm.

With a wide selection of materials and shaft sealing systems they are suitable to handle nearly all kind of liquids which are usual in the above mentioned industries. For example we call light fuels (all kinds), acids, lyes, solvents, hydrocarbons, heat transfer liquids, heavy fuel, liquid sulphur, melted plastics, bitumen ect.

For handling hot water above 190°C (375°F), our pump types NHL are available.

Relevant documents on request.

Design

The DICKOW centrifugal pumps type NCL are single-stage, single-flow volute casing pumps in back pull out design, with an end suction flange and a centerline discharge flange. Bearing housing with intermediate casing, shaft sealing and impeller is mounted to one unit.

With the back pull out design, unit can be removed without demounting the pipe connections.

If spacer type couplings are used, the motor can also remain bolted on the base plate.

Volute casing

The pump casing of standard design is cast in one piece and foot mounted on the base plate. The casing is sealed to the atmosphere by confined non-asbestos gaskets.

If required, following special designs are available:

Volute casing with heating jacket

Pumps with heating jacket are required if the liquid temperature decreases when flowing through the pump or when the liquid temperature drops below the melting or cristallization point.

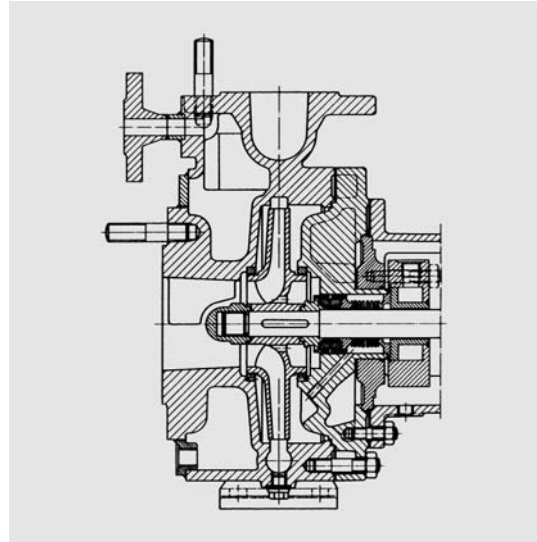

For example: Dimethylterephthalat (DMT), sulphuric liquid, Phenol etc.

Heating jackets on volute and intermediate casings with welded cover are designed for heating liquids up to 24 bar / 350 psi and 220°C / 430°F.

Centerline-mounted casing

API 610, requires centerline-mounted pressure casings, if the pumping fluid temperatures are 177°C (350°F) or higher. All NCL-types can be delivered with centerline supported pressure casings.

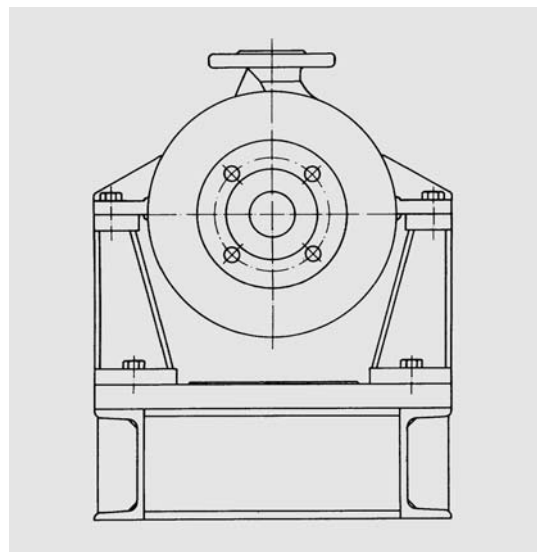

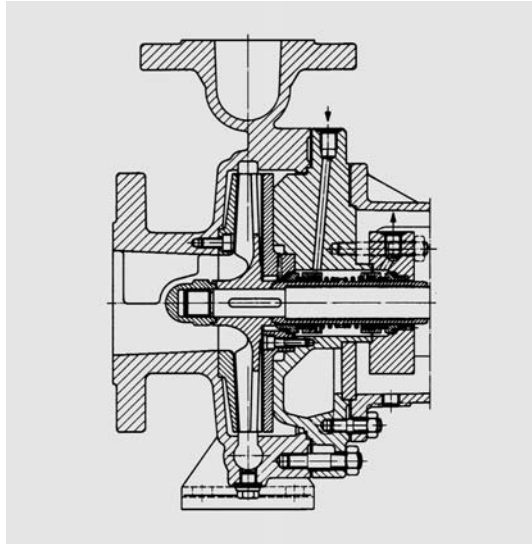

The shaft construction guarantees a critical speed of more than 10% over the maximum operating speed. The connections "cap screw – hub" and "hub – shaft sleeve" are sealed by confined gaskets and the pump shaft has no contact to the pump fluid.

Bearing

The pump shaft is carried by generously dimensioned antifriction bearings outside the pumped liquid. The bearings are oil lubricated. The oil level is regulated by constant level oiler.

Double-row angular ball bearings of Conrad-type (no filling slots) on coupling side, roller bearing on pump side. Service life 25000 hours at continuous operation.

Impeller

Closed impellers are standard. Impellers are casted in one piece with solid hubs. To minimize the axial load of the bearings, the impellers are fitted with wear rings on the back and balance holes to the suction. Impellers are properly statically and dynamically balanced in acc. to DIN ISO 1940T1 Grade 6,3.

For handling liquids, containing solids such as slurry and suspensions up to discharge 3", the NCLo-type with open impeller is available.

NCLo-pumps are fitted with renewable wearing disks on suction side to minimize maintenance costs. For discharge sizes 4" and bigger semi-open impellers are available.

The overhung mounted impellers are secured on the shaft by means of a key and a cap screw with Heli-Coil insert.

Bearing housing

Bearing housings of NCL-pumps are of split design. Therefore, it is possible to supply the pump sided bearing bracket lantern of corrosion resistant material when handling aggressive liquids.

The pump sided radial seal ring located in the bearing bracket lantern is protected by an additional deflector which avoids entrance of leakage from mechanical seal. The bearing bracket lantern is designed as drip pan and provided with leakage connections.

If required, bearing bracket cooling is also available.

Wear rings

Volute casing and intermediate casing of NCL-types are both fitted with renewable wear rings held in place by a press fit with locking screws. Additional impeller wear rings available as an option. The running clearances are in accordance with API 610.

Shaft, shaft sleeve

The pump shaft is able to transmit the full driver output and is accurately machined throughout his entire length and is properly finished at the bearing surfaces.

In order to have satisfactory seal performance the shaft diameter and overhung are sized to minimize shaft deflection at the seal faces.

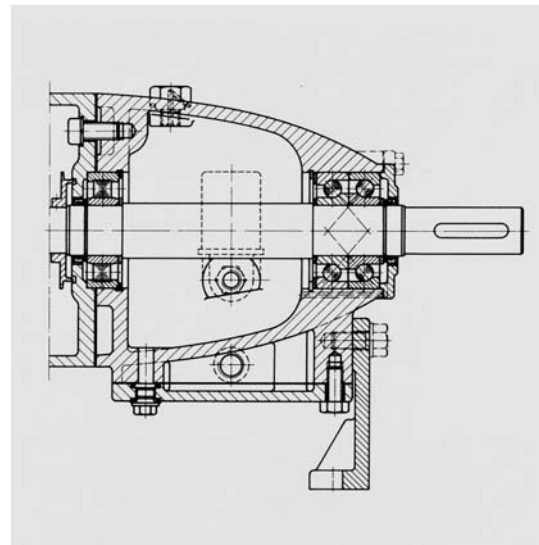

NCL-Design

volute casing
foot mounted

replaceable
wear ring

drain plug

closed impeller

confined gasket

seal chamber

heavy duty
antifriction
bearings

bearing bracket
oil lubricated

deflector

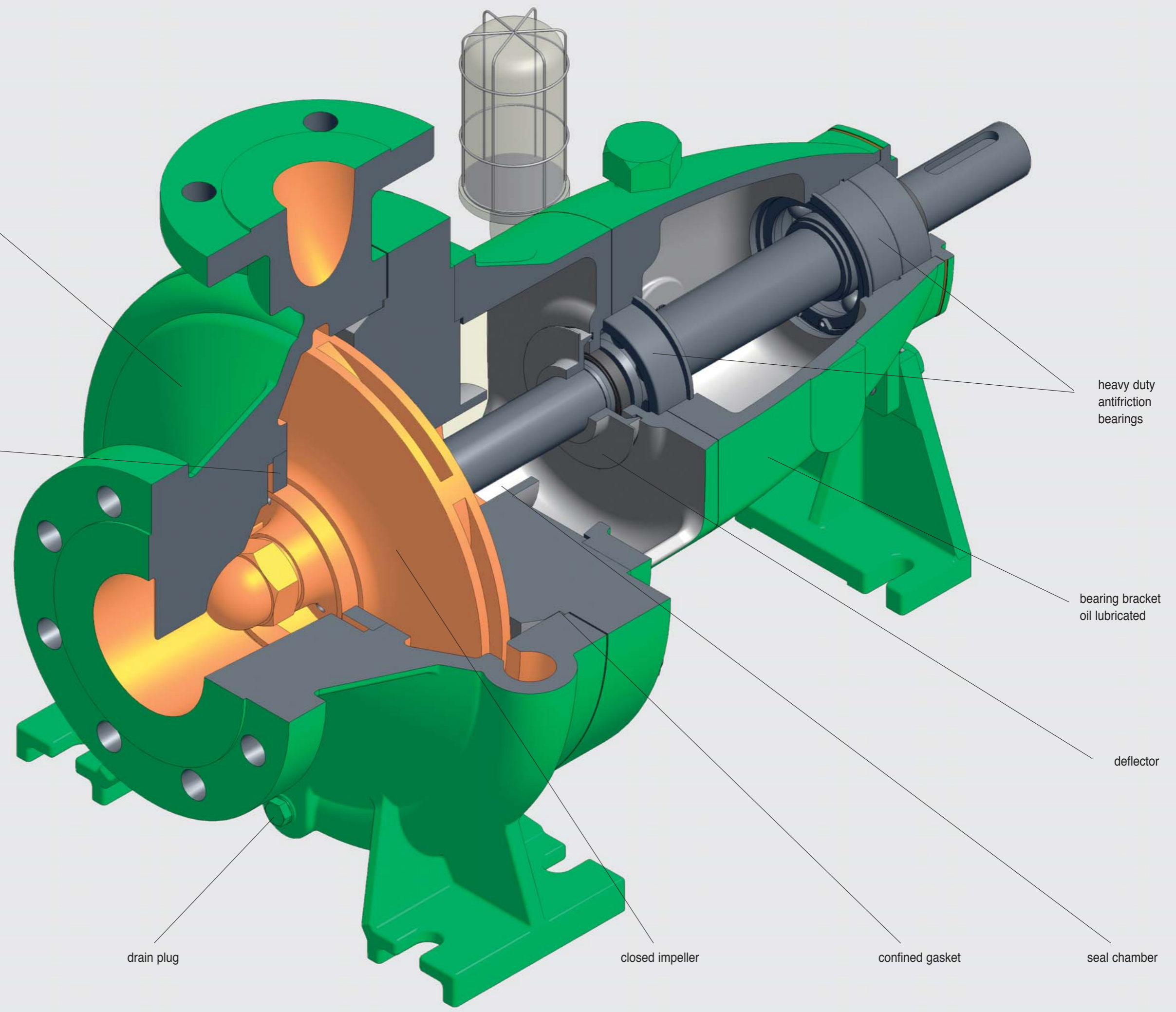

Interchangeability of spare parts

To have the advantages of a fine subdivided performance range with many pump types without disadvantage of a large spare part stock, the NCL-types are designed in a unit-composed system. Therefore you need for all sizes of pumps only four bearing sizes, four mechanical

seal sizes, four shafts a.s.o. Further, many parts in different pump types are similar and interchangeable with another.

The possibilities of interchangeability are shown in the following table.

Size of bearing housing		I/25						II/32						III/42						IV/53																		
Part No.	Pump size	32/165	40/165	50/165	32/210	40/210	50/210	65/165	80/165	65/200	80/200	100/200	32/250	40/250	50/250	65/250	80/250	40/320	50/320	100/250	125/250	150/250	65/320	80/320	100/320	125/320	80/400	100/400	125/400	200/260	150/320	200/320	150/400	200/400	150/500	200/500		
102	Volute casing																																					
233	Impeller																																					
512.1/2	Wear ring						●					▲	▲		●					▲	●		▲	●		▲	●		▲	●		▲	●		▲	●		▲
422	Cap screw																																					
113	Intermediate casing	▲	▲	●	●	●	▲	▲	●	●	●	▲	▲	▲	▲	▲	▲	▲	▲	▲	▲	▲	●	●	●	▲	▲	▲	▲	▲	▲	▲	▲	▲	▲	▲	▲	
330	Complete bearing unit with shaft and lantern																																					
524	Shaft sleeve																																					
	Complete shaft sealing unit with accessories																																					
400.5	Gaskets	▲	▲	●	●	●	▲	▲	●	●	●	▲	▲	▲	▲	▲	▲	▲	▲	▲	▲	▲	▲	▲	▲	▲	▲	▲	▲	▲	▲	▲	▲	▲	▲	▲	▲	▲

not interchangeable
 interchangeability with similar color and symbol

Application limit

Hot water up to 190°C / 374°F (NCL s + NCL hu)

Thermal oils up to 350°C / 662°F (NCL s + NCL hu)

Pressure limits:

- NCL s – 20 bar / 290 psi – 190°C / 374°F
- NCL hu – 24 bar / 348 psi – 100°C / 212°F
- (16 bar / 232 psi – 350°C / 662°F)
- NCL h – 16 bar / 232 psi – 100°C / 212°F

Higher pressures on request

Materials

The following specified materials are standard design. Further materials are available on request.

Pump type	NCL s		NCL hu		NCL h	
Ext. casing parts	Ductile iron	GGG-40.3	Cast steel	GS-C 25	Stainless steel	1.4408
Impeller	Cast iron	GG-25	Cast iron	GG-25	Stainless steel	1.4408
Intermediate casing	Ductile iron	GGG-40.3	Cast steel	GS-C 25	Stainless steel	1.4408
Shaft	Carbon steel	1.4021	Carbon steel	1.4021	Carbon steel	1.4021
Shaft sleeve	Stainless steel	1.4571	Stainless steel	1.4571	Stainless steel	1.4571
Cap screw	Carbon steel	St 60	Carbon steel	St 60	Stainless steel	1.4571
Bearing housing	Cast iron	GG-25	Cast iron	GG-25	Cast iron	GG-25
Lantern	Cast iron	GG-25	Cast iron	GG-25	Cast iron	GG-25

Shaft sealing

Stuffing box

Stuffing boxes are fitted with split cages and split stuffing box ring for an easy replacement of packing rings. Internal circulation or external flushing is possible.

Mechanical seals can be installed in the stuffing box chamber on site, no re-machining of parts required.

Mechanical seal

Pumps can also be fitted with all kind of mechanical seals such as single, tandem or double seals.

Heating or cooling of the seal is possible. Single seals can be equipped with throttle bushings, quench connections or auxiliary stuffing box. Seal glands are fitted with confined non-asbestos gaskets to prevent blow outs.

Mechanical seals for special service conditions

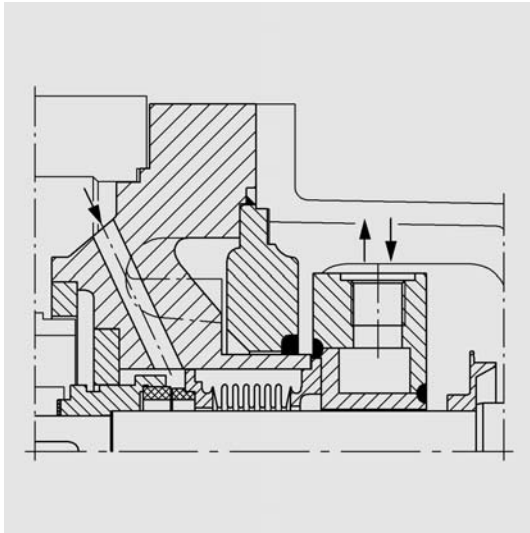

Single mechanical seal with heating jacket, system DICKOW N6b, bellow type, to handle DMT, Sulphur etc.

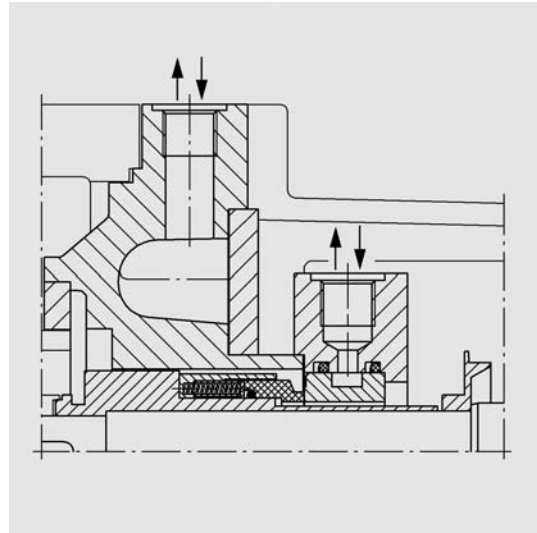

Single mechanical seal with water cooled seal ring, Burgmann H75G15, to handle hot water up to 190°C / 374°F.

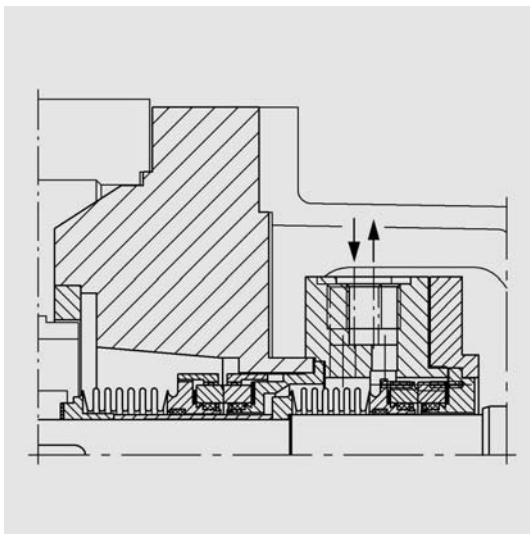

Tandem mechanical seal with Plan 52, system DICKOW N9, bellow type, to handle heat transfer oil up to 350°C / 660°F.

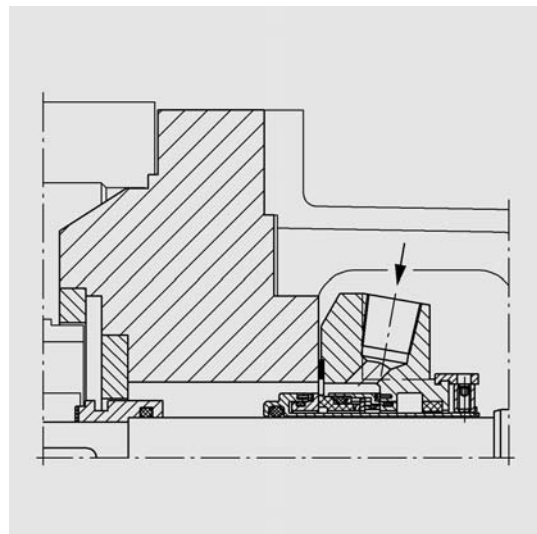

Single mechanical seal, cartridge type, for quick and easy maintenance.

Performance range

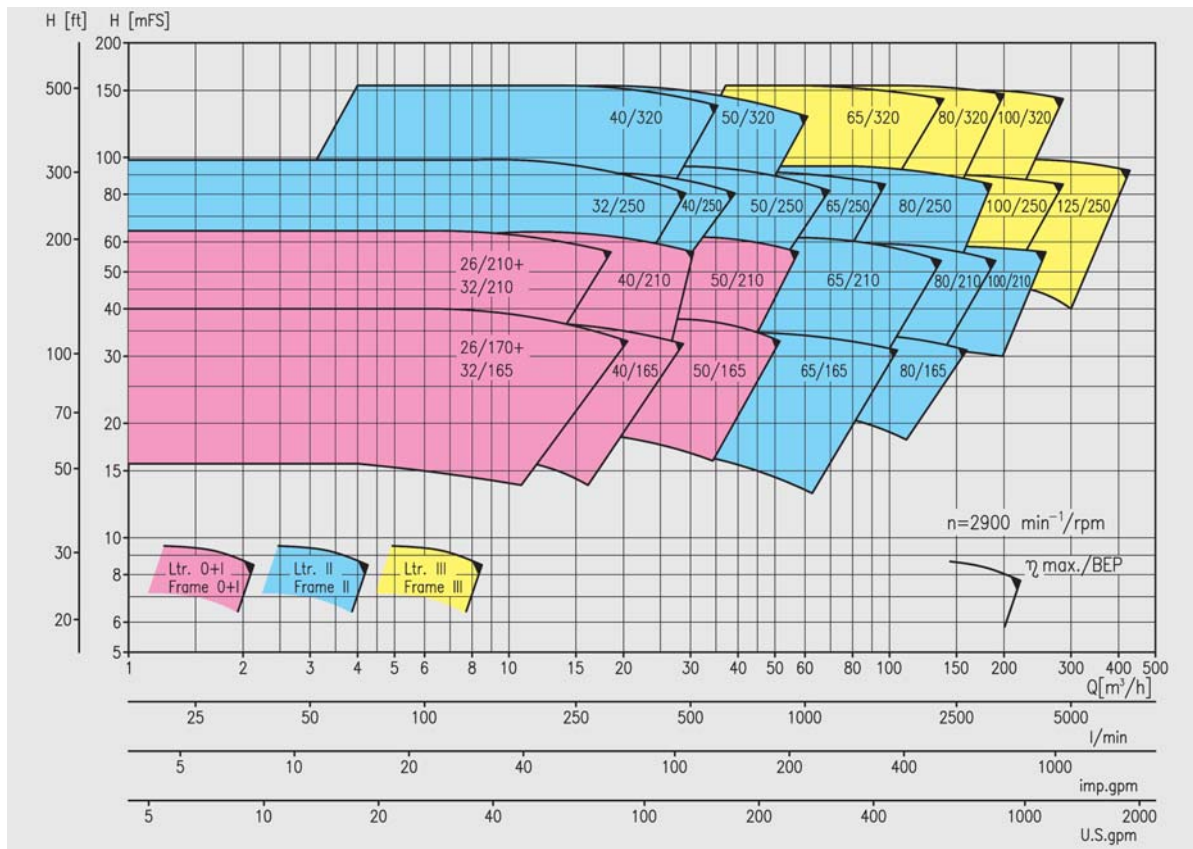
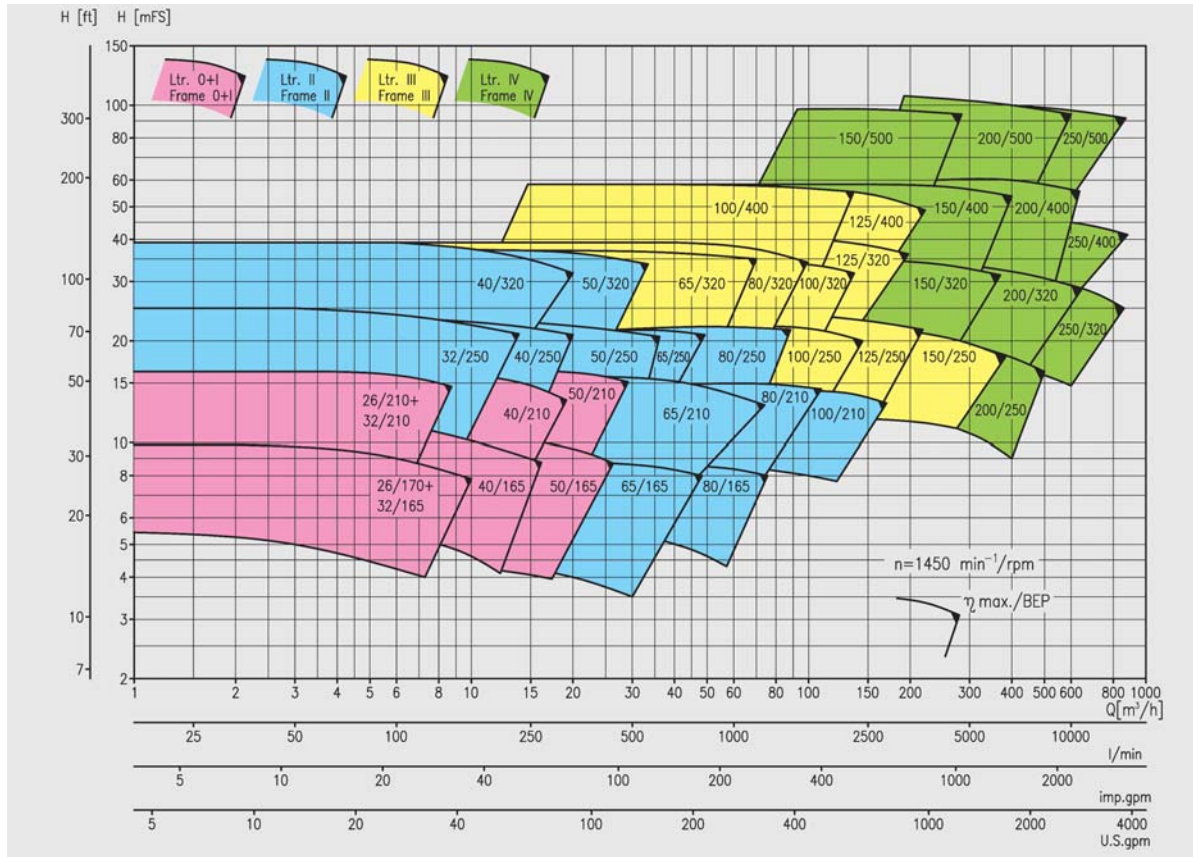

Performance curves for the individual pump sizes, also for 1750 / 3500 rpm, with NPSH-values and power consumption, are available on request.

